

P C

T H E

i M M O R T A L ™

A M I G A

S T



Produced under license from Electronic Arts Limited.
Software © 1990 Will Harvey. All Rights Reserved.
© 1990 Electronic Arts. All Rights Reserved.

Contents

Loading Instructions - Amiga	3
Loading Instructions - Atari ST	4
Key Commands	6
Game Controls	6
Use the Joystick to Move	7
Combat	7
Using Items In Your Pack	9
Notes On Using Items	11
Pausing the Game	11
Getting Out of Pit Traps	12
Increase Vitality By Sleeping	12
Climbing Up and Down Ladders	13
Completing a Level of the Labyrinth	13
Restarting a Game or Level	14
Copy Protection	16
Guide to Level 1	17
Codex of the Serpent	26
Level 1	27
Level 2	33
Level 3	38
Level 4	42
Level 5	44
Level 6	47
Level 7	48



he morning sun heats the jagged peaks as you follow the forgotten road down to the valley floor. The bleached ruins of great columned temples and towering citadels rise from the grassy plain like the bones of some colossal beast. This was the ancient city of Erinoch, destroyed by dragon's fire over 1000 years ago. Mordamir spoke often of this city...and the labyrinth below...

Mordamir. You think back to the days when you were young and eager to learn to the spells of sorcery. The old wizard Mordamir took you in and patiently taught you the arts of magic. He taught you how to read the runes and unleash their power. The power of charms and fire. He showed you the strength of steel and taught you to use your wizard's cunning. Mordamir was your master, your mentor. He was your guide down the treacherous path of wizardry. He was your friend.

Many years have passed since you last saw the old man. You assumed he was dead — that is, until a few nights ago, when he called to you in a dream. You woke with the uneasy feeling that Mordamir still lived — trapped in a bottomless cavern. And so you set out to unravel the secrets of the Immortal.



Loading Instructions Amiga

To play The Immortal, you need an Amiga with 1 MB of memory and a joystick. Note: The Immortal does not support hard drives or any extra drives.

To play The Immortal:

1. Remove any disks from your floppy drives.
2. If your computer is on, turn it off. Plug your joystick into joystick port 2.
3. Boot your computer as you normally would. At the Workbench prompt, insert the Boot Disk into df0:.
4. Your computer will prompt you to insert the Play Disk. Remove the Boot Disk from df0: and insert the Play Disk. The game will load automatically.
5. Once the game is loaded, the credits will go by. Press the joystick button to continue.

Note: Accelerated Amigas not supported. If the game won't run properly with your accelerator card, disable the card or turn it down to a lower speed.

Loading Instructions

Atari ST

To play *The Immortal*, you need an Atari 520ST or 1040ST with 1 MB of memory, at least one double-sided drive, and a joystick.

To play *The Immortal*:

1. Remove any disks from your floppy drives.
2. If your computer is on, turn it off. Plug in your joystick.
3. Insert the Boot Disk into drive A. If drive A is single-sided and drive B is your only double-sided drive, see the instructions below under *If Drive A is Single-Sided...*
4. Turn on your computer. The game will boot automatically.
5. Follow the onscreen instructions. Once the game is loaded, the credits will go by and the game will start.

If Drive A is Single-Sided...

If your A drive is single-sided, do the following:

1. Boot your Atari as you normally would.
2. Insert the Boot Disk into drive B.
3. From the desktop, move the cursor to the Boot Disk icon and double-click to open the window.
4. Move the cursor to the BOOTD2 icon and double-click.
5. Follow the onscreen instructions. Once the game is loaded, the credits will go by and the game will start.

Error loading file: MAZE0.CNM

If you receive this loading error, you didn't insert the Play Disk when the computer requested it. Repeat the loading instructions above and make sure you follow the onscreen instructions.

Key Commands

Music On/Off

To turn the music off, press **Ctrl-S**. Press **Ctrl-S** again to turn the music back on.



Restart

To restart a game or level, press **Ctrl-R**. See *Restarting a Game or Level* in this manual for details.

Quitting the Game

To quit *The Immortal*, remove the disk from your floppy drive and turn off your computer.

Game Controls

You begin in the antechamber that leads to Level 1.



Vitality

Vitality is life. Run out of Vitality and you're dead. You lose Vitality when monsters inflict damage on you. If you run out of Vitality, you have to start the level over (see *Restarting a Game or Level*).

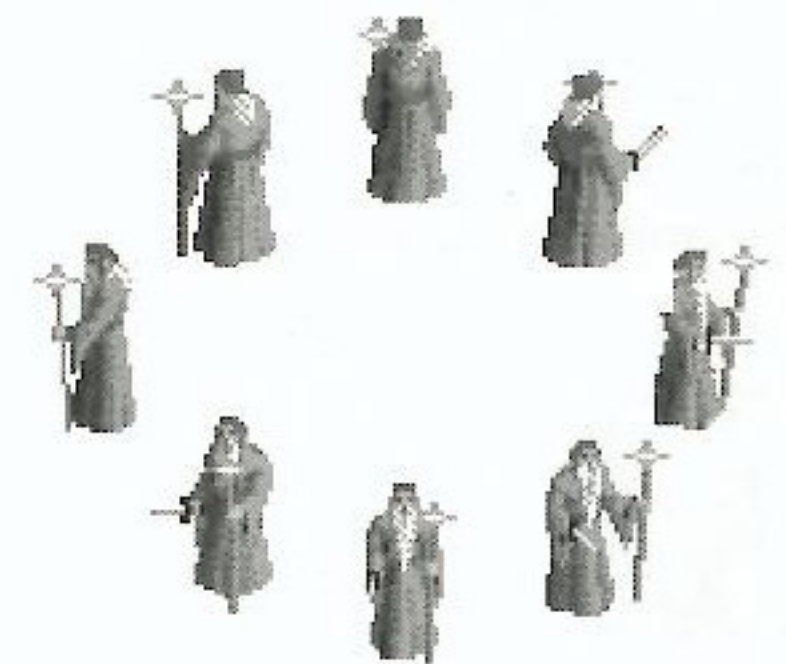
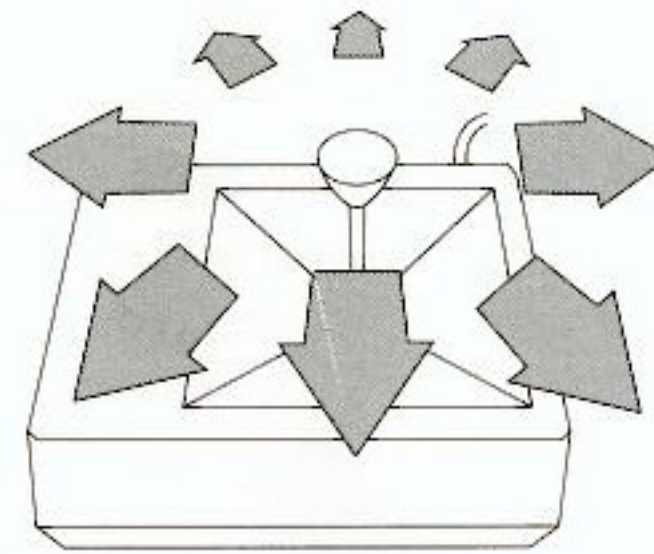
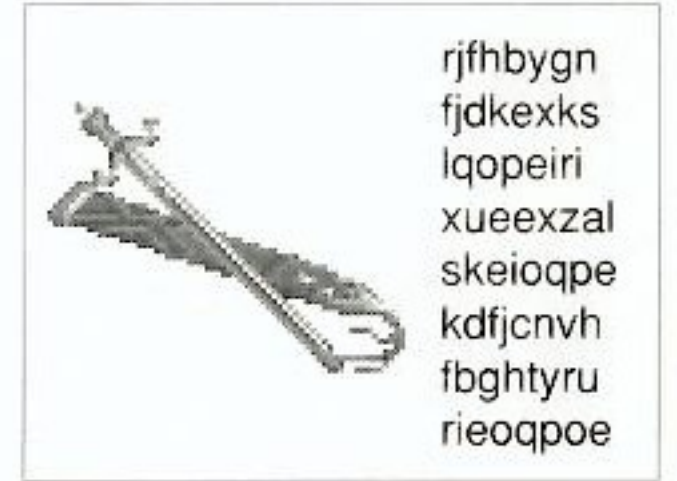

Use the Joystick to Move

Combat

When a monster attacks, you must fight to the death. The best strategy is to parry when your opponent is about to strike, and attack when he's leaving himself open.

Attacking

Jab



Push forward.

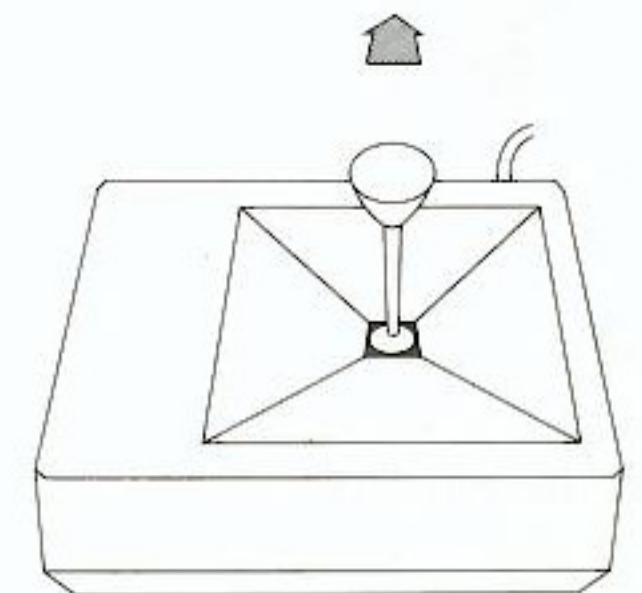

Slash

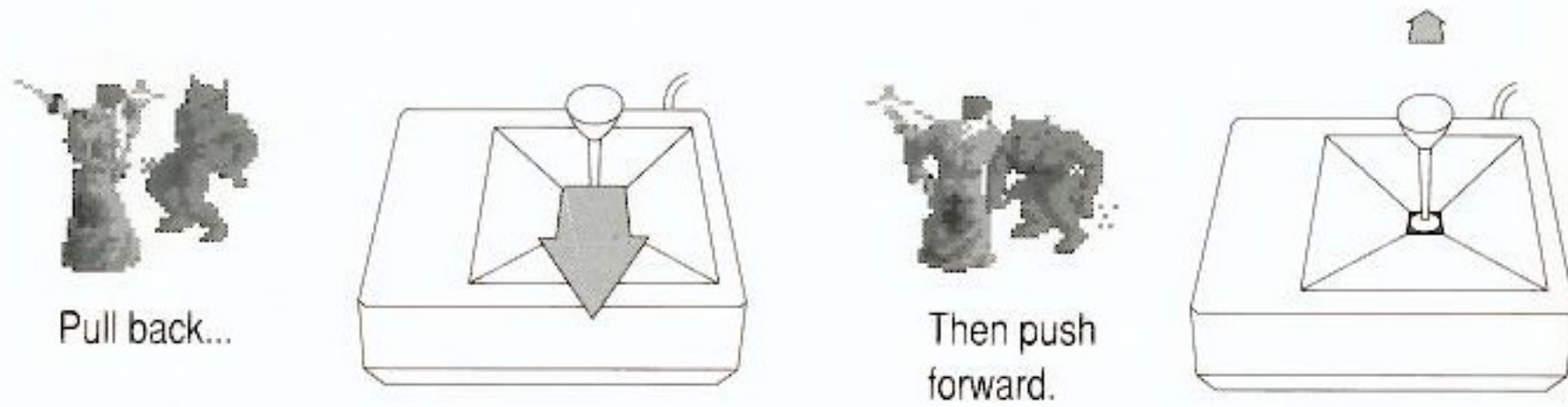

Parrying

To parry, move the joystick RIGHT and LEFT.

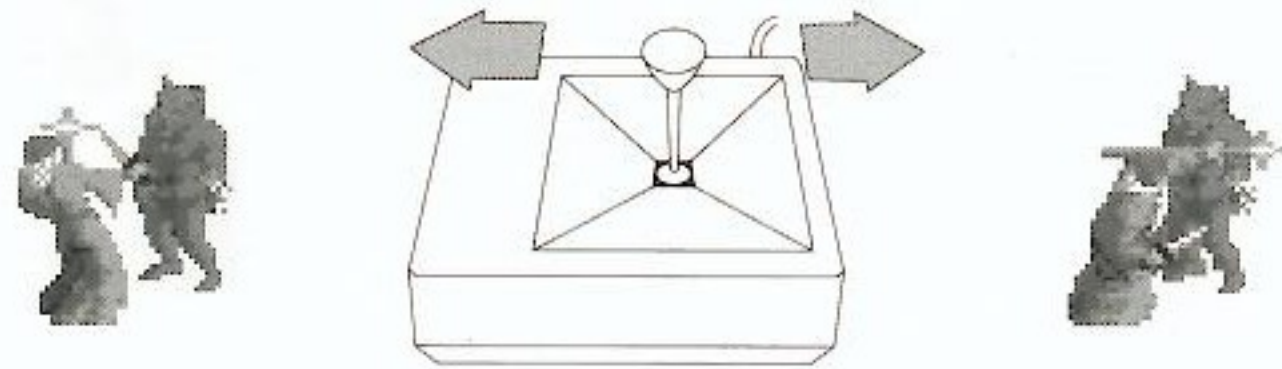

If the wizard is facing you, the movements are reversed.

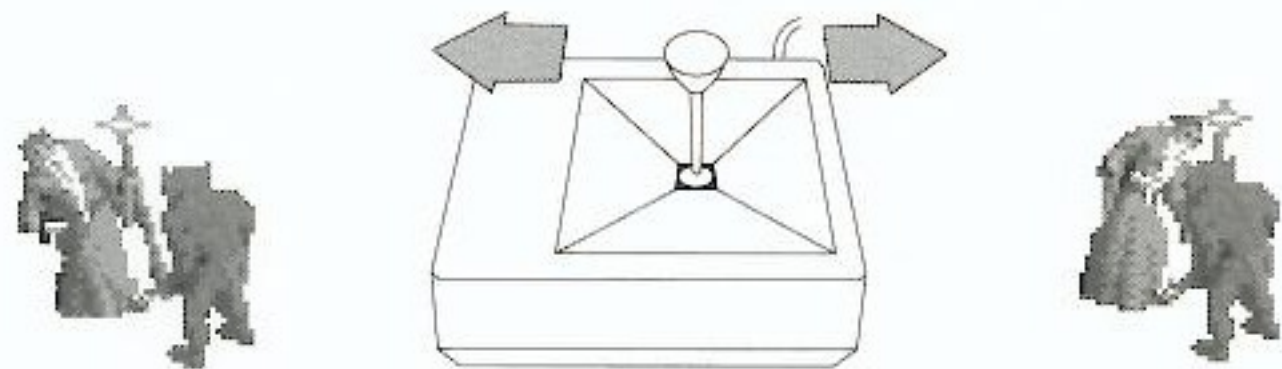

Fighting when the wizard is facing you may be tricky at first. It's easy though if you remember to always move the joystick in the direction you want the wizard to lean.

Lean Away From the Monster's Swing To Parry His Blow

Your opponent has to pull back his weapon before he can swing. When you see him pull back, lean in the direction his swing will travel.



When he pulls back, lean away from his weapon.



Using Items In Your Pack

You carry a Pack where you keep the valuable items you find. To look at the items in your Pack, press the **spacebar**. (Apple IIGS users: Press joystick button A.) To *use* an item from your Pack, move the cursor to the item and press a joystick button.

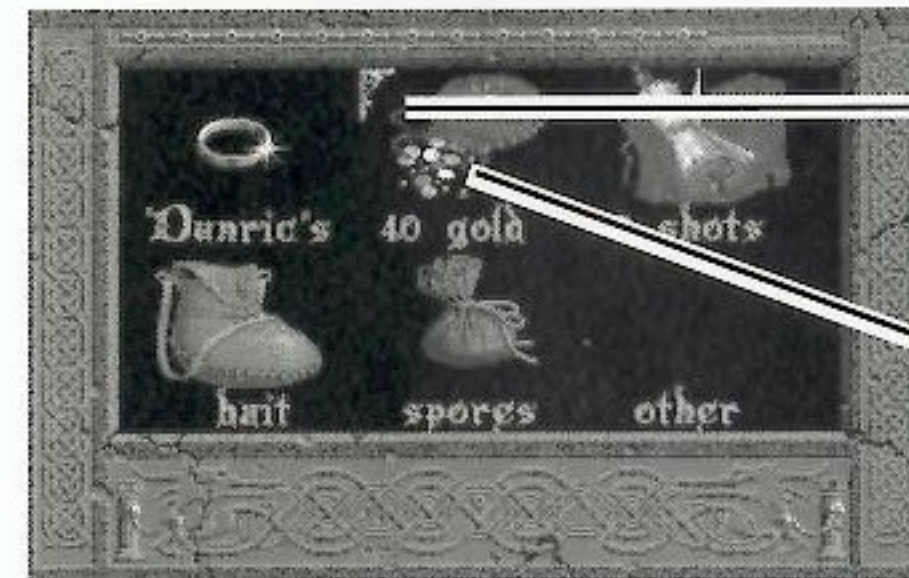

Use the joystick to move the cursor.

Press a joystick button to select the item.



To view other items in your Pack, highlight **other** and press a joystick button.

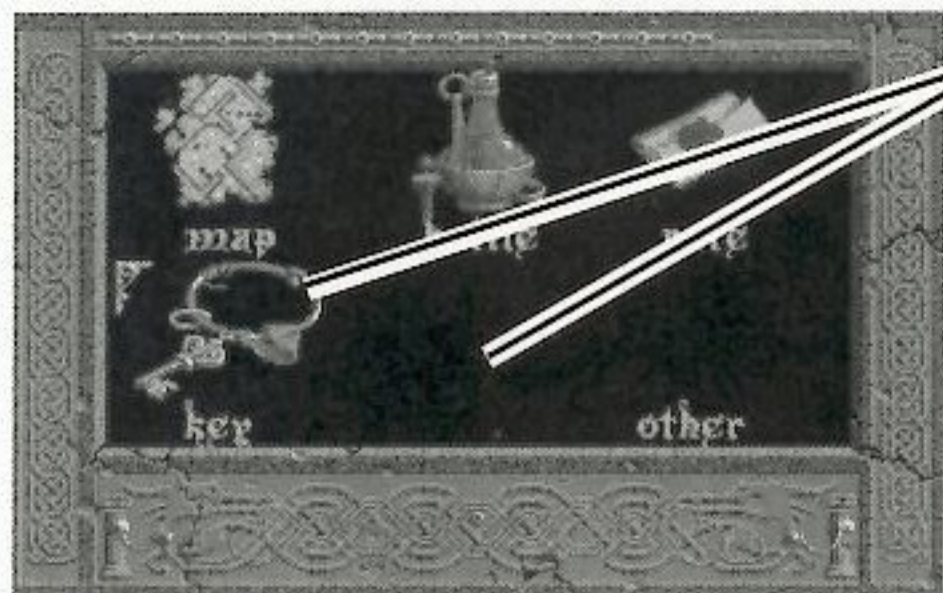

To GO BACK TO THE ACTION, move the cursor to a black square and press the joystick button. You can also select your gold or key to go back to the action. (Don't worry — you can't drop keys or gold).

Most items are activated simply by selecting them. A few, however, require additional commands:



Blink Spell — Once you've selected the Blink Spell, press the joystick button to blink. Apple IIGS users: Press joystick button B.



Carpet — Select the Carpet to ride through the air. Select it again to deactivate.



Fireball Spell — Once you've selected the Fireball Spell, press the joystick button to cast a fireball. Apple IIGS users: Press joystick button B.

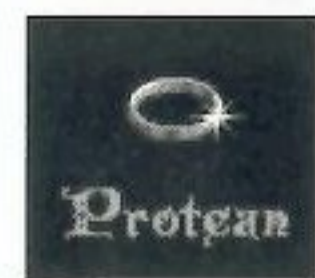

Protean Ring — Select the Protean Ring to activate its magic power. Select it again to deactivate. Note: You can't climb ladders while in goblin form.

Don't Drop Items You'll Need Later!

Sometimes *using* an item consists of setting it on the ground — for example, you use a gem by setting it down. Be careful! If you set an item down in the wrong place, make sure you pick it up again before you leave or you won't find it in your Pack!

Notes On Using Items

Each kind of item has a specific use — Spores can only be planted in dirt, while the Troll Ritual Knife can only be thrown. You can't control *how* an item is used, just when and where. Most items are useful only in a particular place — one of the most challenging parts of the game is figuring out which item the situation demands.

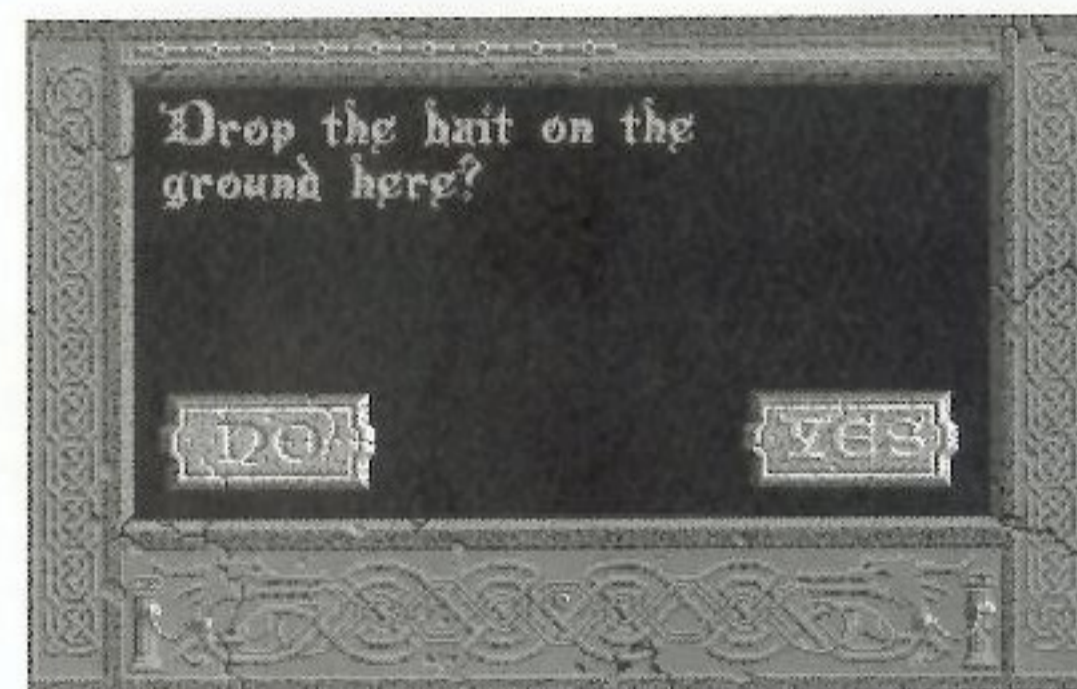

When you first get an item, there's no way to know what it does until you try it. You can guess an item's general use — you wear rings, you drink potions — but you can't know an item's magical properties until you try it.

Pausing the Game

If you need to pause the game, press the **spacebar** to bring up your Pack. (Apple IIGS users: Press joystick button A.) When you're ready to go back to the action, move the cursor to a black square or your gold and press a joystick button.

Getting Out of Pit Traps

There are deadly pit traps in the labyrinth — if you're not careful you may find yourself hanging by your staff over rows of iron spikes. Fortunately, there's always a chance of swinging out before your staff breaks.



kcjghtbf
hdjghybi
knojkle
bxvcbnds
ndheggcf
dvxfsscd
fhtgrybg
fvvhnjui

To swing out, gently rock the joystick back and forth at an even pace.

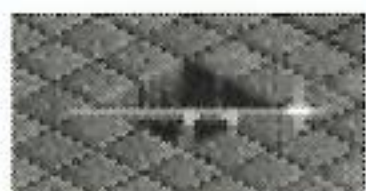

If you fall in...



...swing out!

Increase Vitality By Sleeping



Piles of straw provide comfortable, SAFE places to rest and regain Vitality. To sleep, move onto the straw and just stand there. After a moment, you'll lie down and go to sleep. PAY CLOSE ATTENTION TO YOUR DREAMS!

Making the Text Scroll Faster

While reading messages, you can hold down the joystick button to make the text scroll faster. You can use this to scroll quickly through messages you've already read, but don't use it as a way to avoid reading messages altogether. Most messages contain important clues you need to finish the game.

Climbing Up and Down Ladders

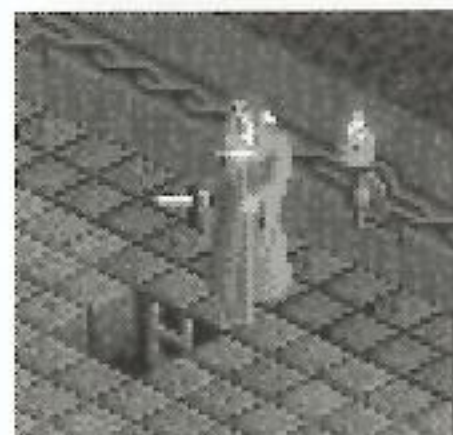

To climb up or down a ladder, move up to it and you'll automatically climb or descend. Be careful going *down* ladders — move only to the side of the opening with the ladder on it or you'll fall to your death.

Completing a Level of the Labyrinth

Whenever you complete a level, you get a certificate. WRITE DOWN YOUR CERTIFICATES AND KEEP THEM IN A SAFE PLACE. If you quit playing The Immortal, you'll need the certificate later so you can start on the level in which you left off.

Once you've written down the certificate, press a joystick button to begin the next level...

...OR quit and start the next level some other time using a certificate.



Only Useful Items Go to the Next Level

Some items only function on a particular level. Before you descend to the next level, the magic of the labyrinth will remove any items you don't need from your Pack.

Restarting a Game or Level

If you die, you can choose to:

- Restart the current level you're on
- Go to a previously completed level
- Start a whole new game

You can also restart a level at any time during the game by pressing **Ctrl-R**.



Press a joystick button.



Restarting the Level You're Currently On

To restart the level you're currently on, leave **NO** highlighted and press a joystick button.

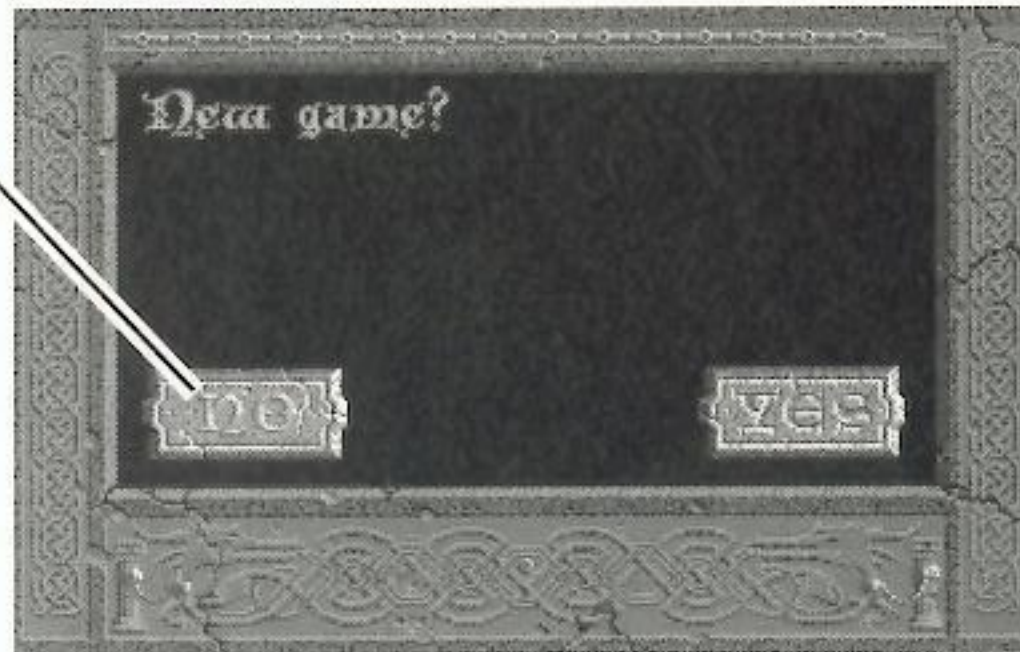

Don't enter a certificate — just press a joystick button.



Going to a Previously Completed Level

To go to a previously completed level, leave **NO** highlighted and press a joystick button.



Type the correct certificate, and then press **Return** or a joystick button. You'll have to answer a copy protection quiz. See *Copy Protection* in this manual.

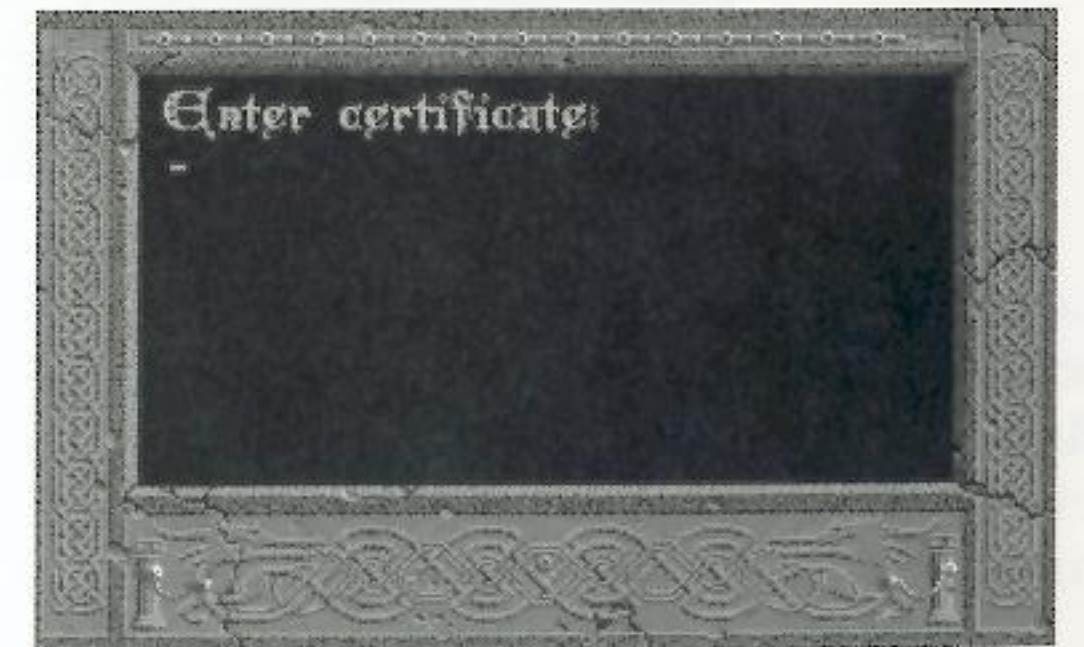

Restarting a Game

To restart the game (Level 1), move the joystick RIGHT to highlight YES and press a joystick button.

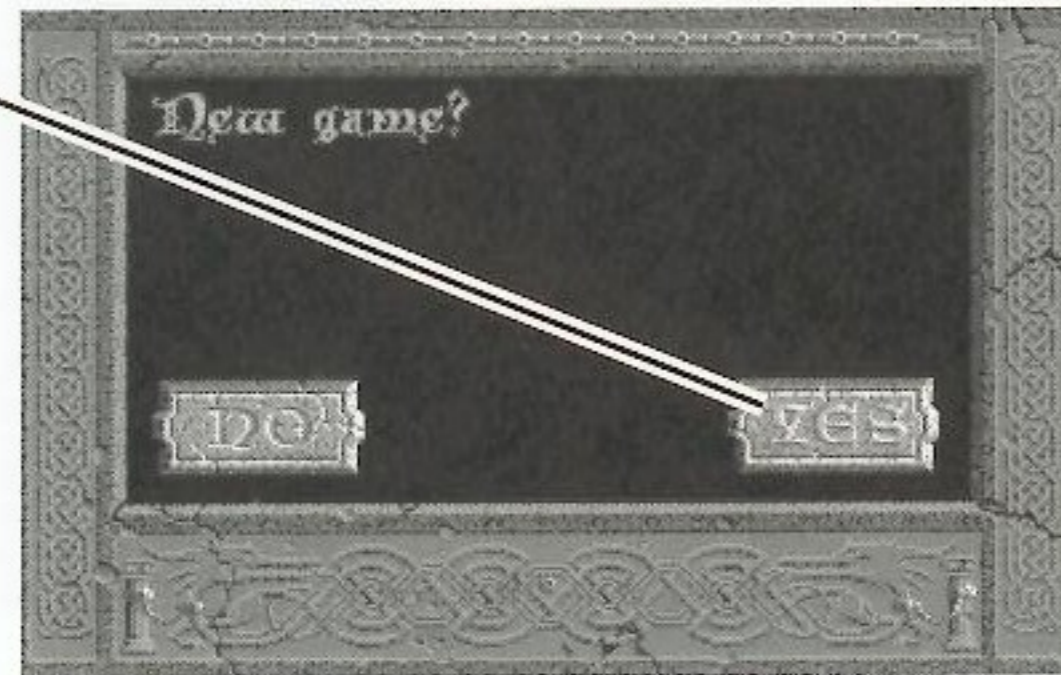

Copy Protection

Occasionally a picture of an item will appear and you'll be asked to enter a letter.

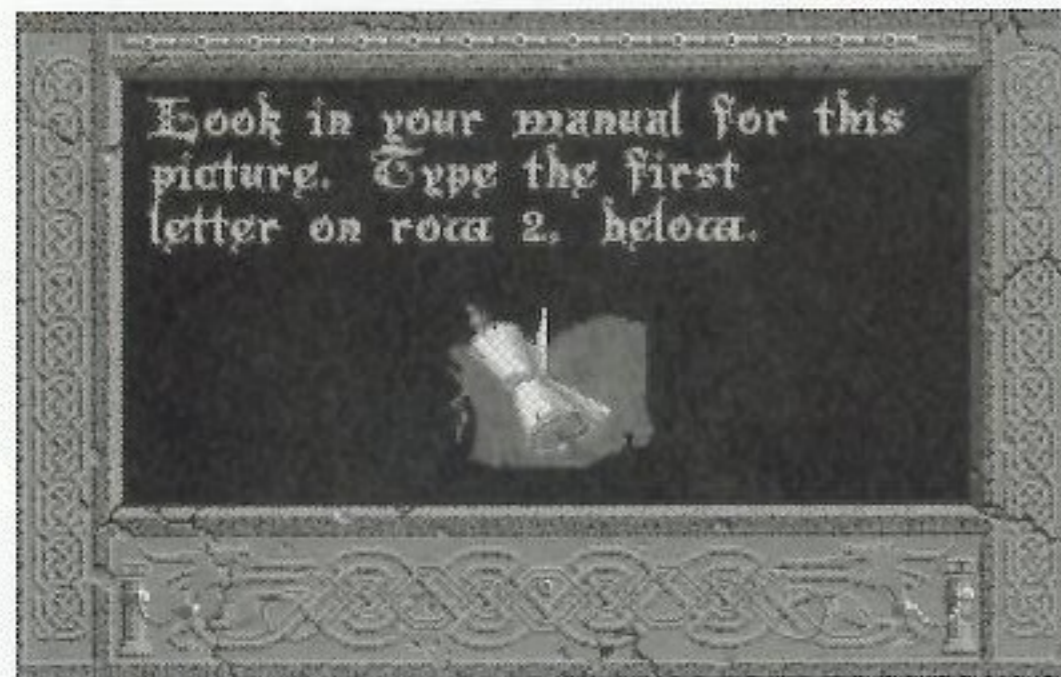

Look for the picture in this manual that matches the one you see on the screen. Find the letter in the table beside the picture, type it and press Return. For example, for the screen shown above you would find the picture of the scroll in this manual. Next you would count down two rows — the correct answer (in this case, the first letter) is g.

Guide to Level 1

1 A Plea for Help

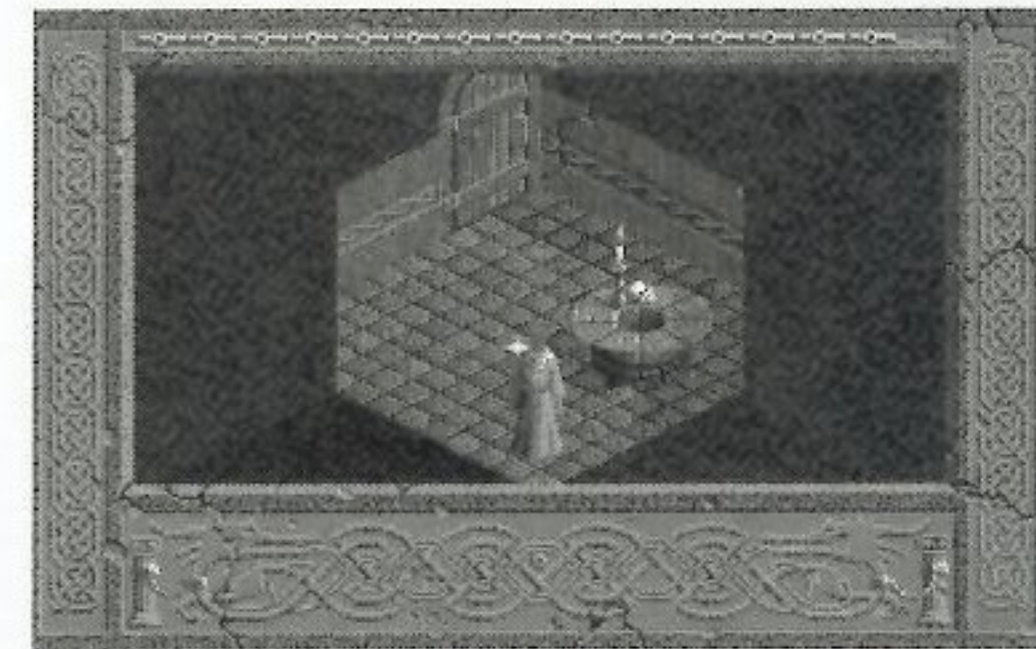

The candle flame leaps and hisses as you enter the small antechamber that leads to the first level of the dungeon. A skull stares vacantly at the dancing shadows on the wall, a grim reminder that *this is no place for mortal men*.

As you approach the table, an image of Mordamir, your lost master in the arts of wizardy, rises eerily from the flame. It speaks...

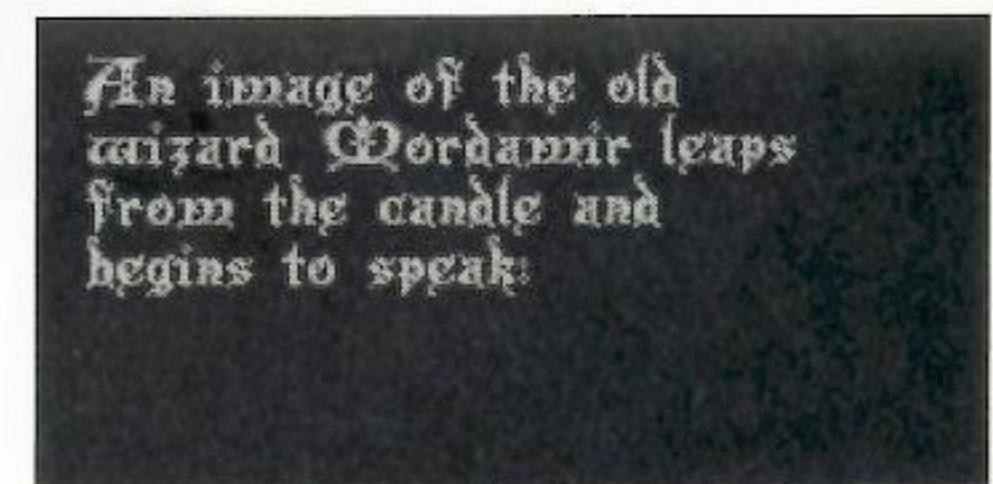
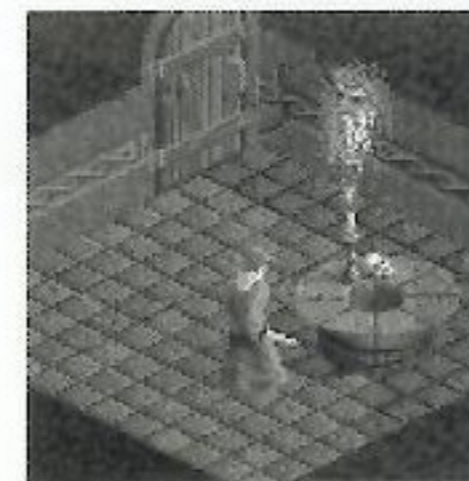

"Mordamir is here!" you whisper. You turn toward the door. "Dunric..." you think, "Another of Mordamir's students, no doubt. The master has taught many in his long life." The thought that you aren't the only one looking for Mordamir comforts you...for the moment.

You'll need to fight very soon, so read the section on Combat before you leave this room.

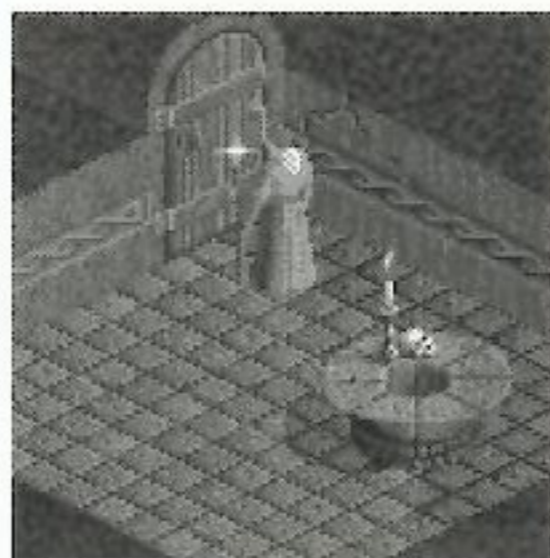

2 Goblin Attack

The sound of clashing steel rings through the air as you enter the long chamber. Before you lies an armored figure — a man — the blood from his wounds still cooling between the tiles of the stone floor.



To your right you hear a snarl. From across the room a giant goblin lumbers toward you, his sinewy muscles rippling as he raises his mace over his head. You raise your sword, readying yourself...



3 Dunric's Servant

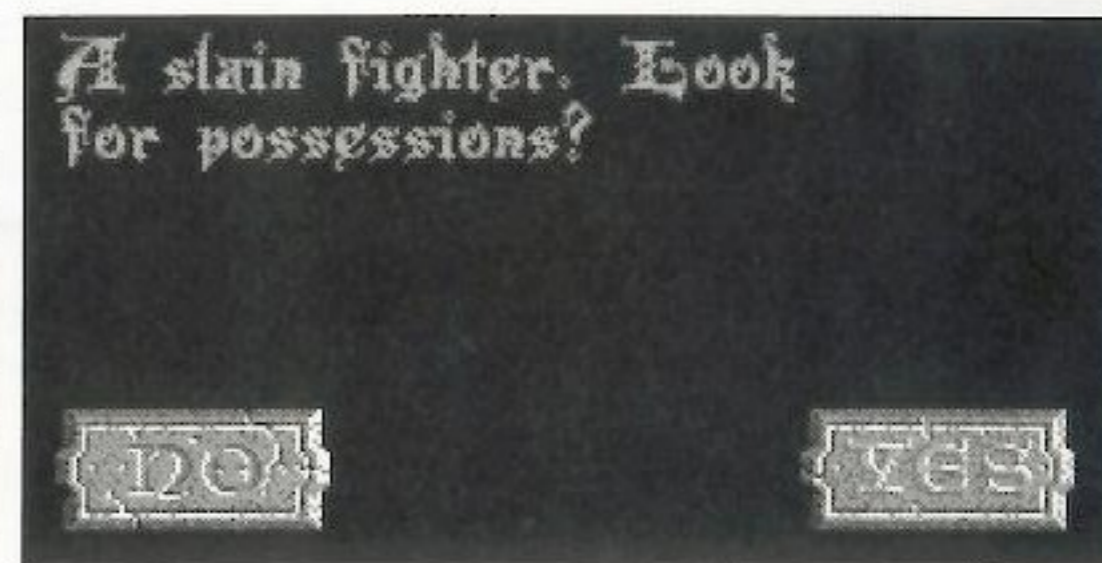

"Who was this unfortunate?" you wonder. You search his body and find a small bag containing a ring and a scroll. Inscribed on the inside of the band is a name: Dunric.

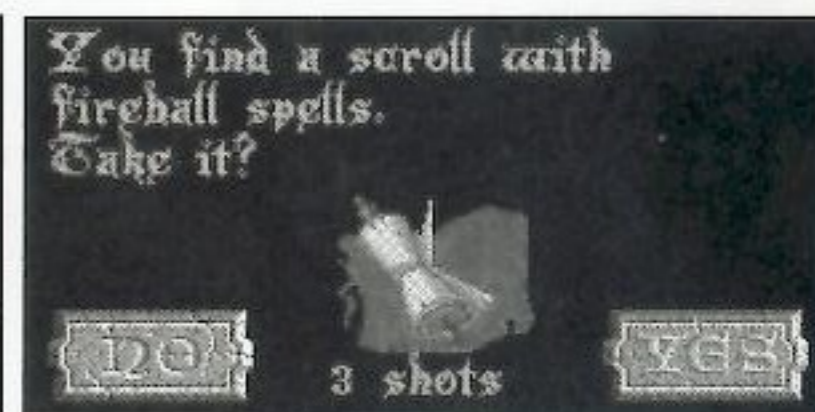
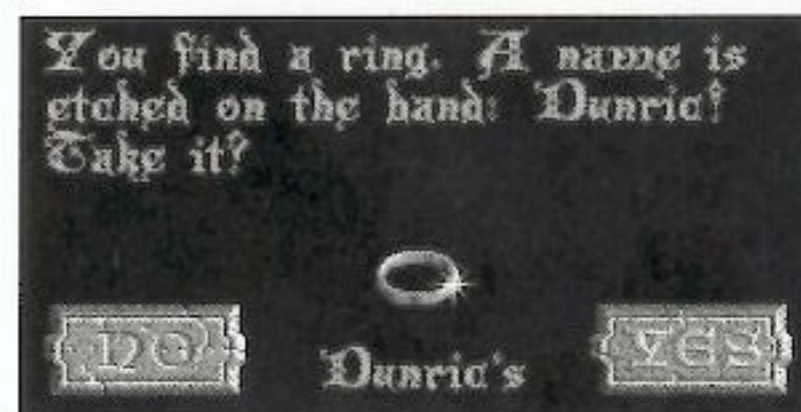

"A fighter wouldn't have need for a scroll or a ring," you think, "This can't be Dunric. Perhaps Dunric's servant..."

The sound of renewed battle shakes you from your thoughts. "Someone else is in trouble," you mutter, picking up your staff...

You can search for items just by moving to the area you want to search. If there is anything of interest in the area, a message will appear telling you what it is.

4 Fire at Your Fingers

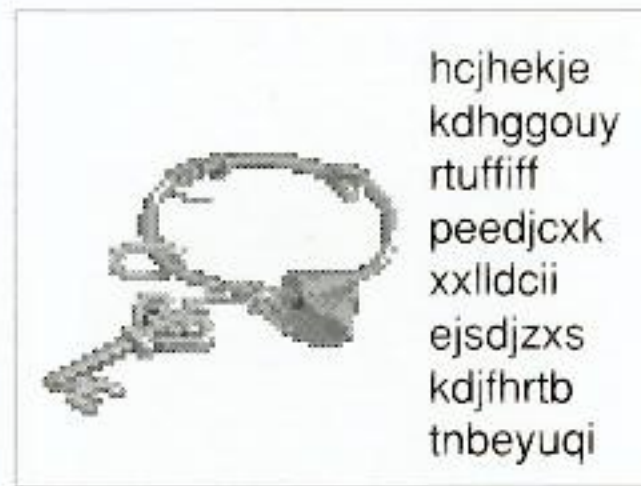

You glance down at the leathery parchment scroll you're clutching and realize you're holding a spell of fireballs. You stop for a moment. Clearing your mind, you read the runes, speaking the arcane words out loud, slowly unraveling the coiled glyphs and weaving together the incantation. A tingling power gathers at your fingertips. You hold the element of fire...

Press the **spacebar** to look through your Pack. (Apple IIGS users: Press joystick button A.) Move the cursor to 3 shots and press the joystick button.



When you're ready to cast a fireball, press the joystick button (Apple IIGS users: Press joystick button B.)

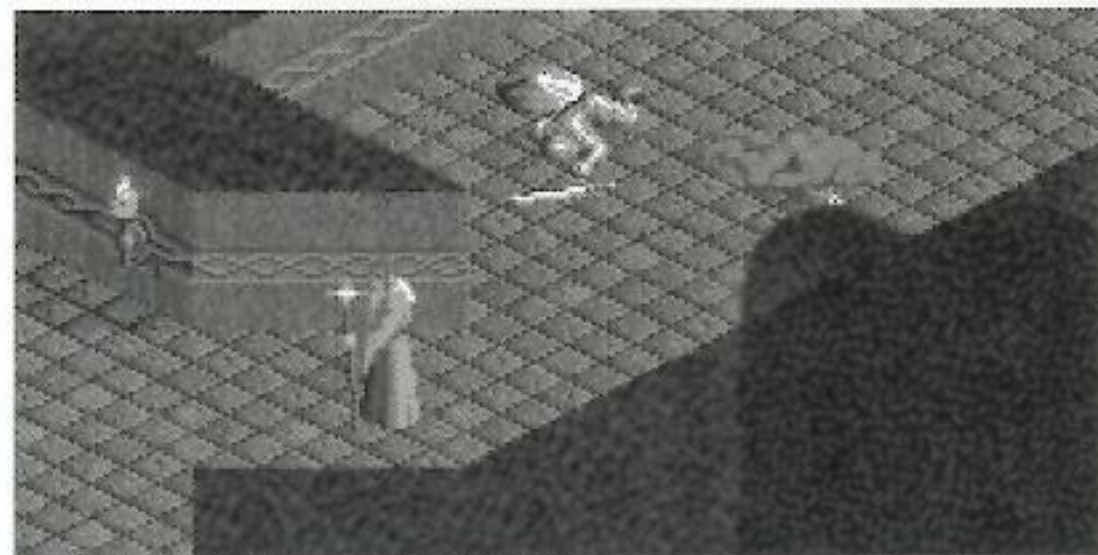

5 Mordamir's Servant



As you round the corner, the frenzied movement of combat immediately catches your eye. A huge goblin, his hands wrapped around the end of a wicked mace, swings furiously at an equally powerful human warrior. The man manages to deflect two blows before he falters and falls back — it's obvious that he's near exhaustion.

Reeling about, the goblin bares his teeth and leaps toward you. "Don't interfere!" he snarls. You could fight him, you think, but your fingertips still itch with the element of fire. The word of power slides easily off your tongue...

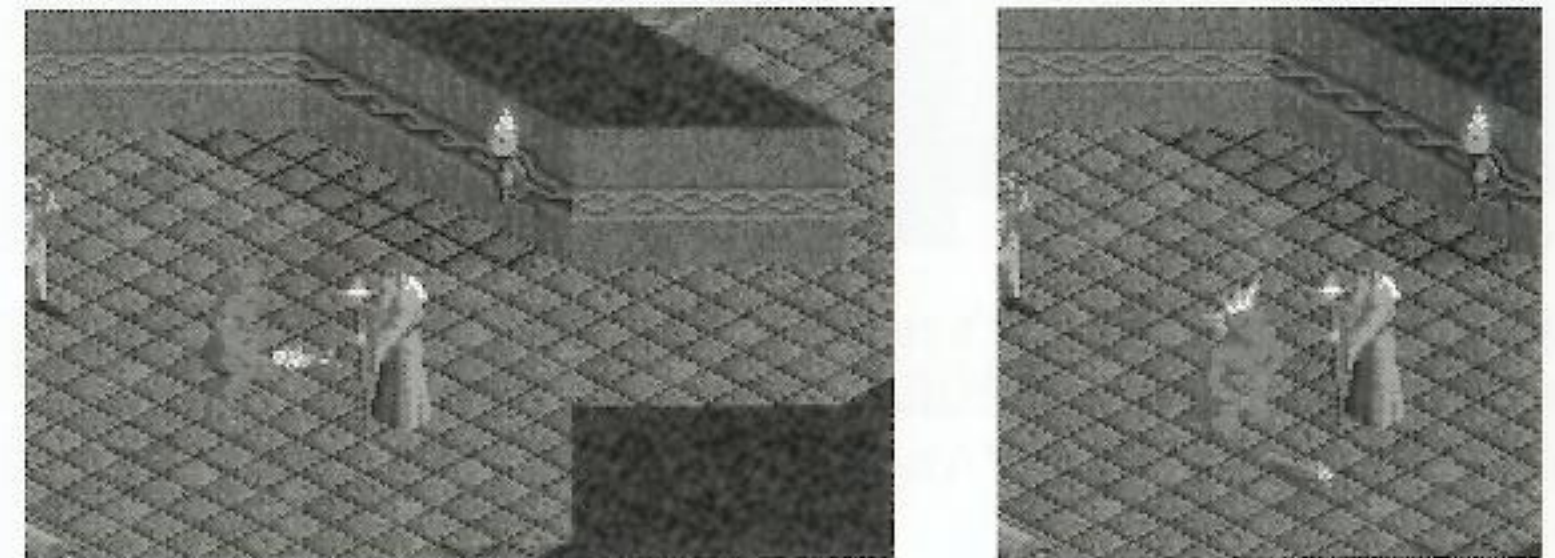

The fireball explodes on the goblin and he falls to the floor. You approach the warrior. "You must find Mordamir," the warrior says. Handing you a key, he hurries out the door.

The key, you discover, opens a nearby chest. Inside the chest you find a collection of strange items: gold, a pouch full of bait, a sack of spores, a bottle containing what looks like normal water, and a tattered map.

You place all the items in your Pack. "May need them later," you think. Slinging the Pack over your shoulder, you slip through the upper door.



6 The Lieutenant's Treasure

You shut the door behind you and look down both ends of the corridor. To your right you discern the shadowy outline of another goblin.

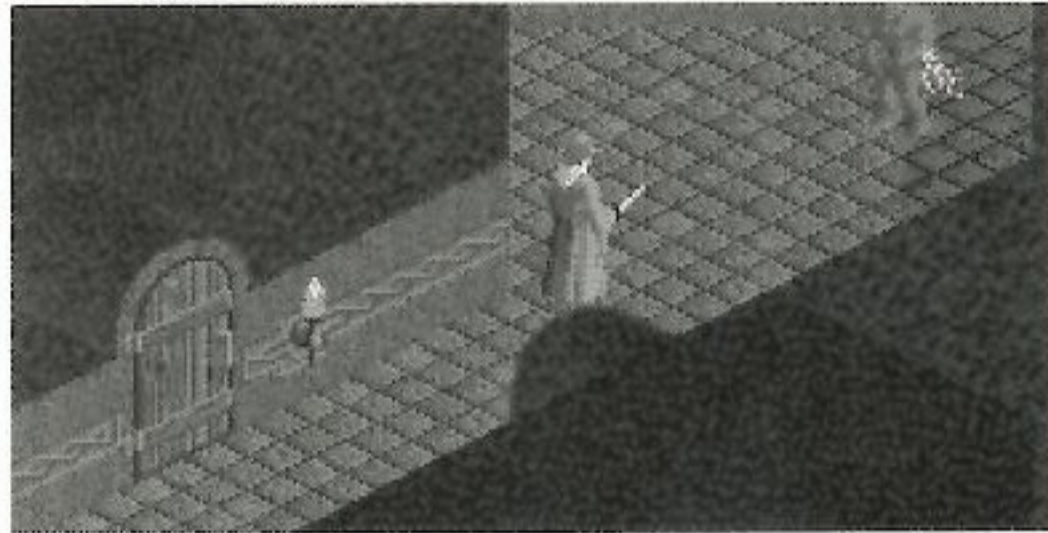

Though he's noticed you, he's not moving toward you. "Two more fireballs," you whisper, lifting your hand, "And this one's for you."



You search the lieutenant and find a note, a key, and more gold. You hastily open the note. The handwriting, you notice, is distinctly human. It almost looks familiar.

"Beware of shades," you read, "They are dangerous, invisible creatures that like darkness. By firelight they cast a shadow by which you can detect and avoid them."

You drop the note and step through the upper door.

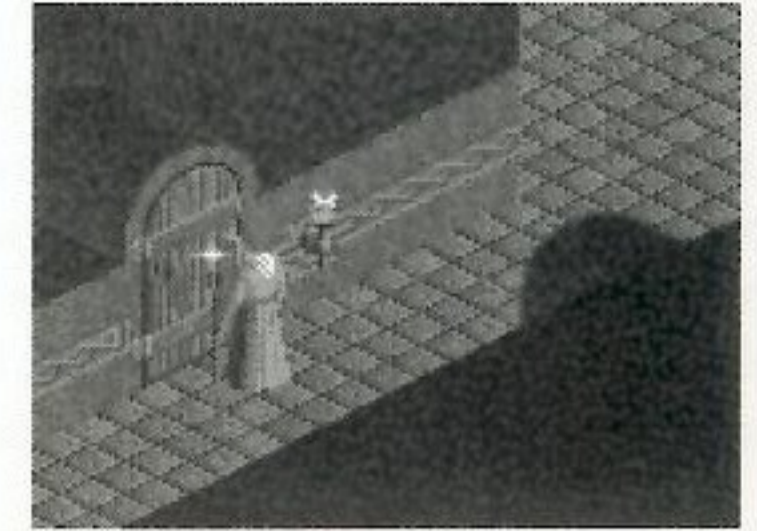

Stone skulls line the walls of the chamber in which you find yourself. Your wizard's sense tells you there's something wrong with this room, but you're not sure what. You've seen this room before...or a picture of it, that is...

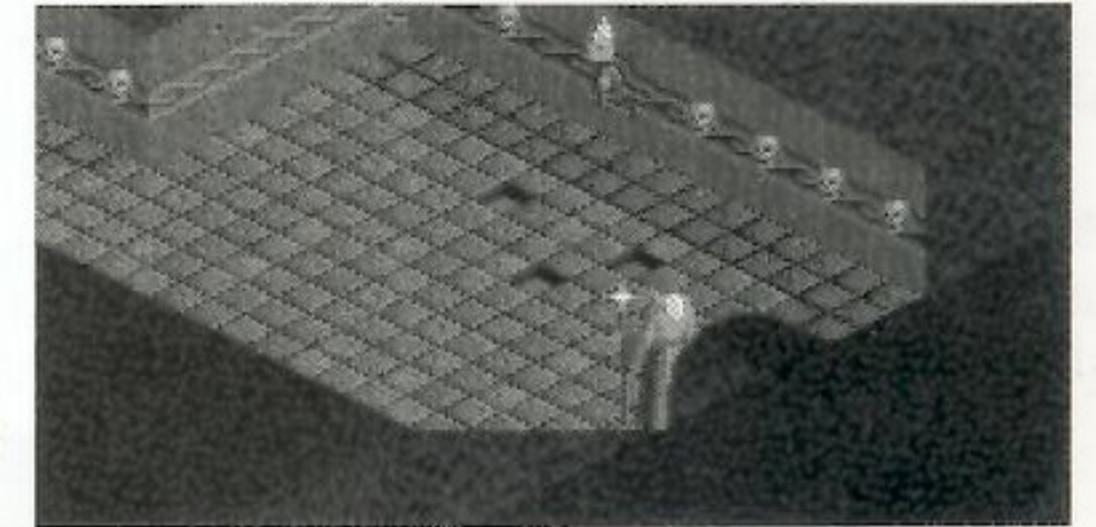

You open your Pack and pull out a musty tome: The Codex of the Serpent.

You'll find The Codex of the Serpent in this manual.

7 Shades in the Shadows

You narrowly escape the flying arrows with your life! You slam the door shut behind you and fall against the wall, catching your breath. But the room you're standing in seems disturbing, too. "More traps!" you curse.

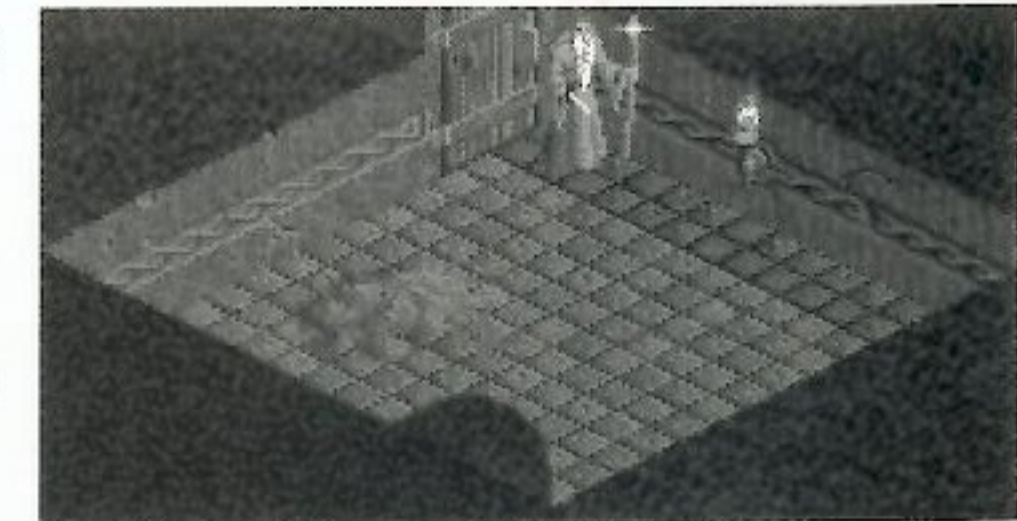

You open your Pack and take out the map you found in the chest. This room *does* resemble one of the rooms traced on the parchment. You notice some conspicuous red dots — they must mark danger. There are red dots marking traps in the next room, too. These are surely the halls of hell! Skirting along the upper left wall, you make your way over to the door.



The door opens into a dark room. You notice that the torches along the wall are out, and suddenly you remember the warning on the note — shades!

A fireball could light the torch. Moving along the wall, you shoot your last fireball. The torch lights, and just ahead you can make out the shadows of two shades.

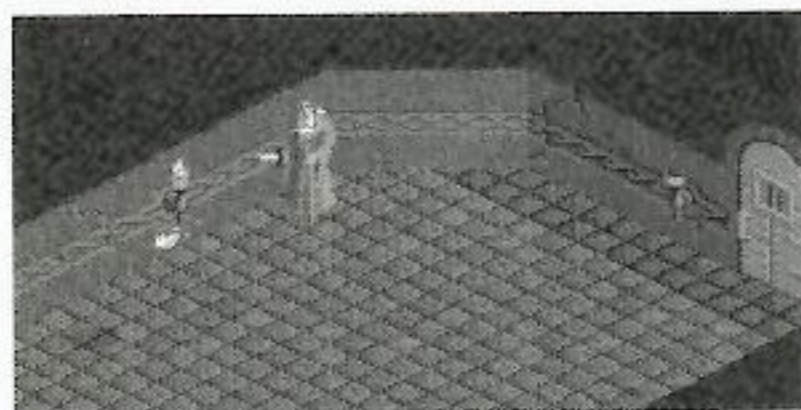
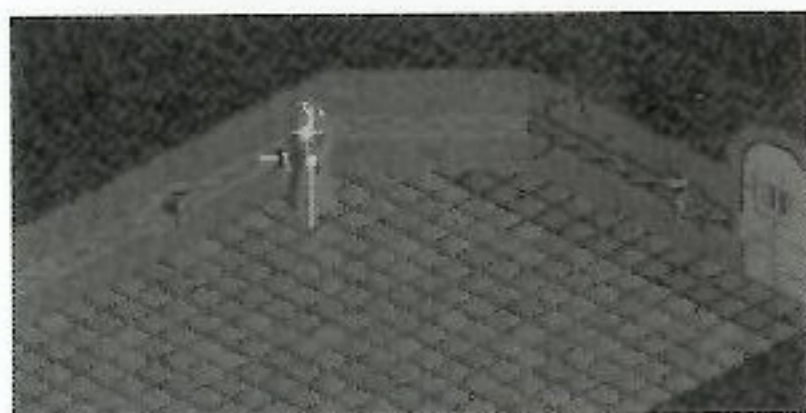

On the far end of the room you make out some objects on the floor. Mindful of the traps and shades, you cross the room and pick up a curious amulet and a spell with which you can charm will o' the wisps. With your eye still on the two shades, you cross down to the door. Locked! Fortunately, you have the key...



8 By the Light of Eternity

In the room you find a deep, abrupt cavern in the dungeon floor. What terrible power, you imagine, could bore such a hole through the earth! No man could perform such a feat! This is the work of a colossal beast. An angry beast...



ktkujihj
ukjnbhlg
kjoipuoj
lkikujyn
bhgbvjhf
jdcgfjop
qjfgghin
tgbuiojn

You notice the beam of light peaking through the dungeon wall. The shaft of light falls on a dial inscribed on the floor. At the end of the dial, embedded in the floor, is a brilliant jewel as large as a man's fist. The jewel and the shaft of light, you imagine, make up a special mechanism of some sort.

You're curious about the mechanism, but at the moment you feel too tired to figure out how it works. You cross over to a cozy pile of straw you noticed in the upper part of the room. Sleep overtakes you quickly, and you dream...

When you wake, you study the mechanism more closely. The sunlight needs to strike the jewel — that much seems obvious. Every year the beam of light inches closer to the jewel. What?! At this rate, the sun won't strike the jewel for another 1000 years! You don't have that kind of time. What mortal does!!

Perhaps if you could reflect the light, you could fool the mechanism...ah, there's the answer!

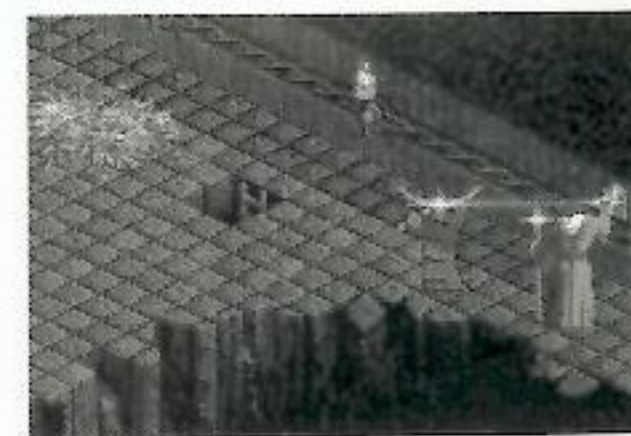
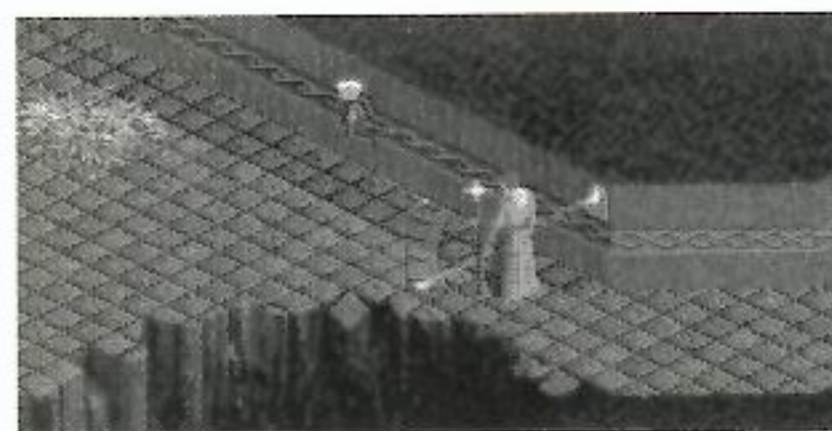

The Codex of the Serpent

Level 1

I, Mordamir, Wizard of the Crimson Keep, wrote these notes for you, my loyal apprentices and students, to explain the mysteries of this dark labyrinth.

Today I go forth to explore the dragon's lair. I hope my wits are keen enough to escape her cunning again! Thus I leave these words for those who may have to come after me. May they keep you from an untimely end in this forsaken place!

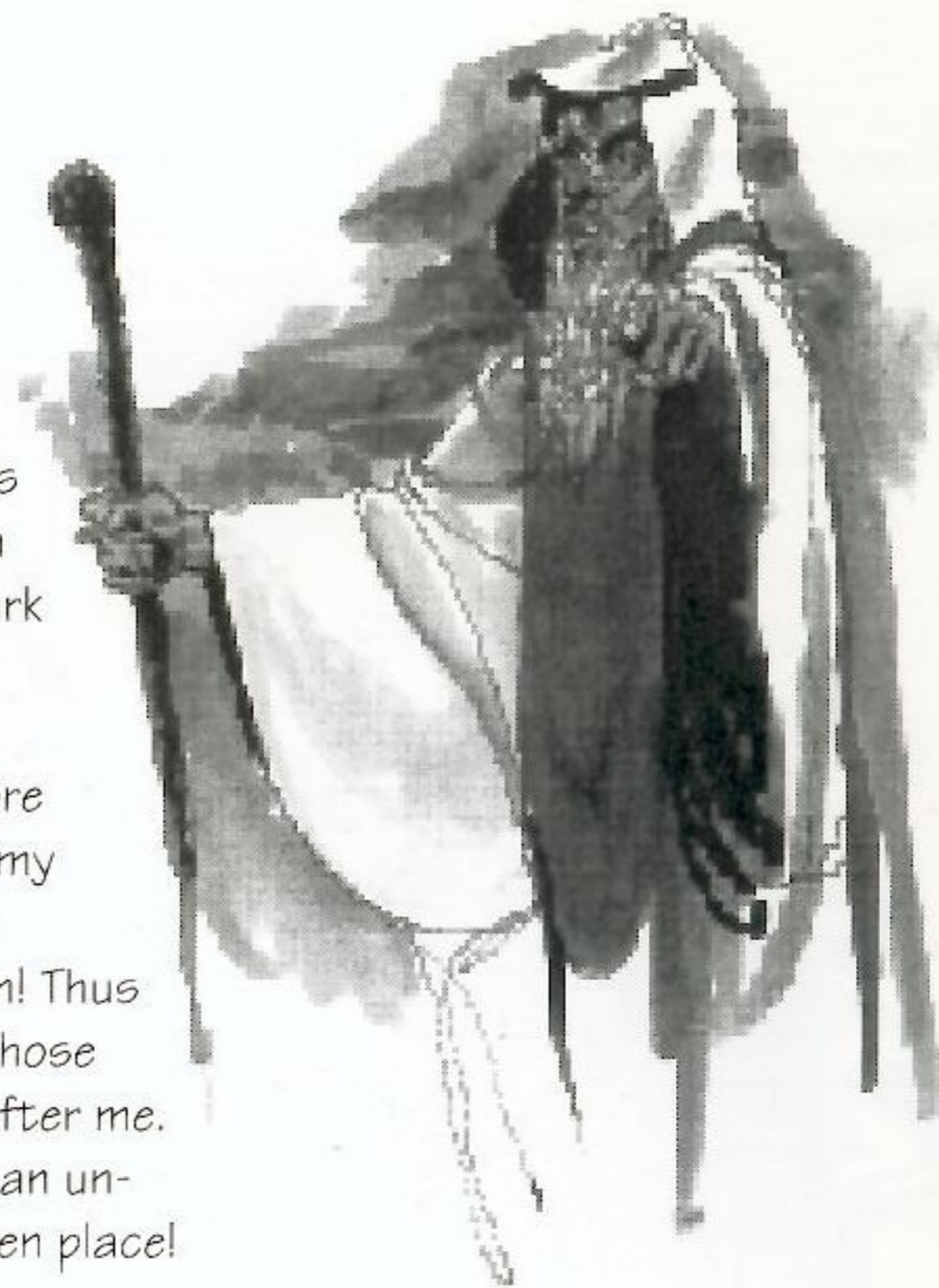

Dunric — my faithful student in the art of wizardry — will be the first to come looking for me. He's often accompanied by Erek, a fighter.



Ulindor — my servant and bodyguard.

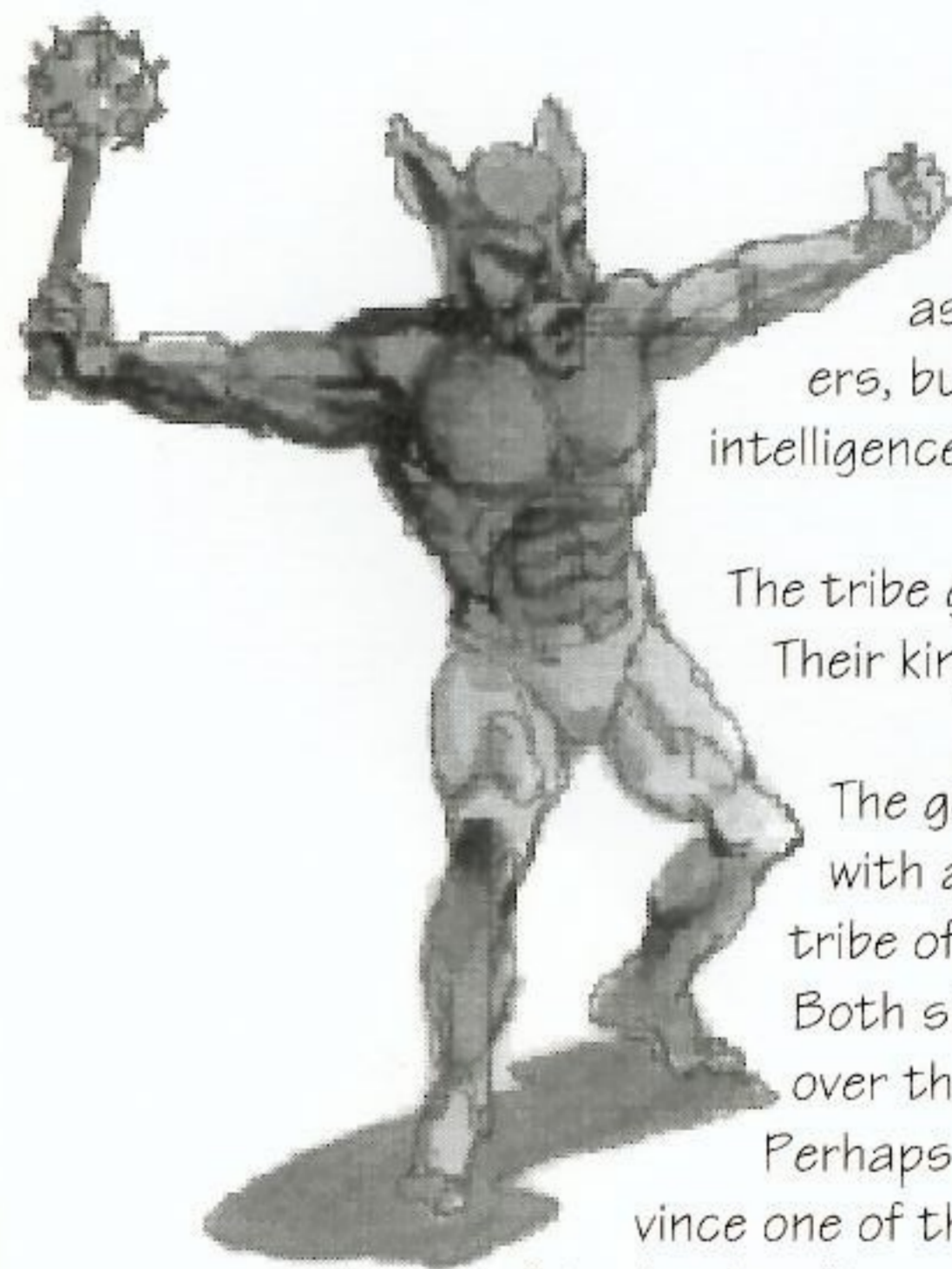

Upper levels — a tribe of primitive creatures known as goblins. Hostile to strangers, but seem to possess reason, intelligence, some ingenuity with tools.

The tribe goes by the name of Druul. Their king is Gresh the Wise.

The goblins are currently at war with a more hostile and powerful tribe of creatures known as trolls. Both sides desperately seek control over the upper levels of the dungeon. Perhaps a show of force would convince one of them that wizards make better friends than foes...

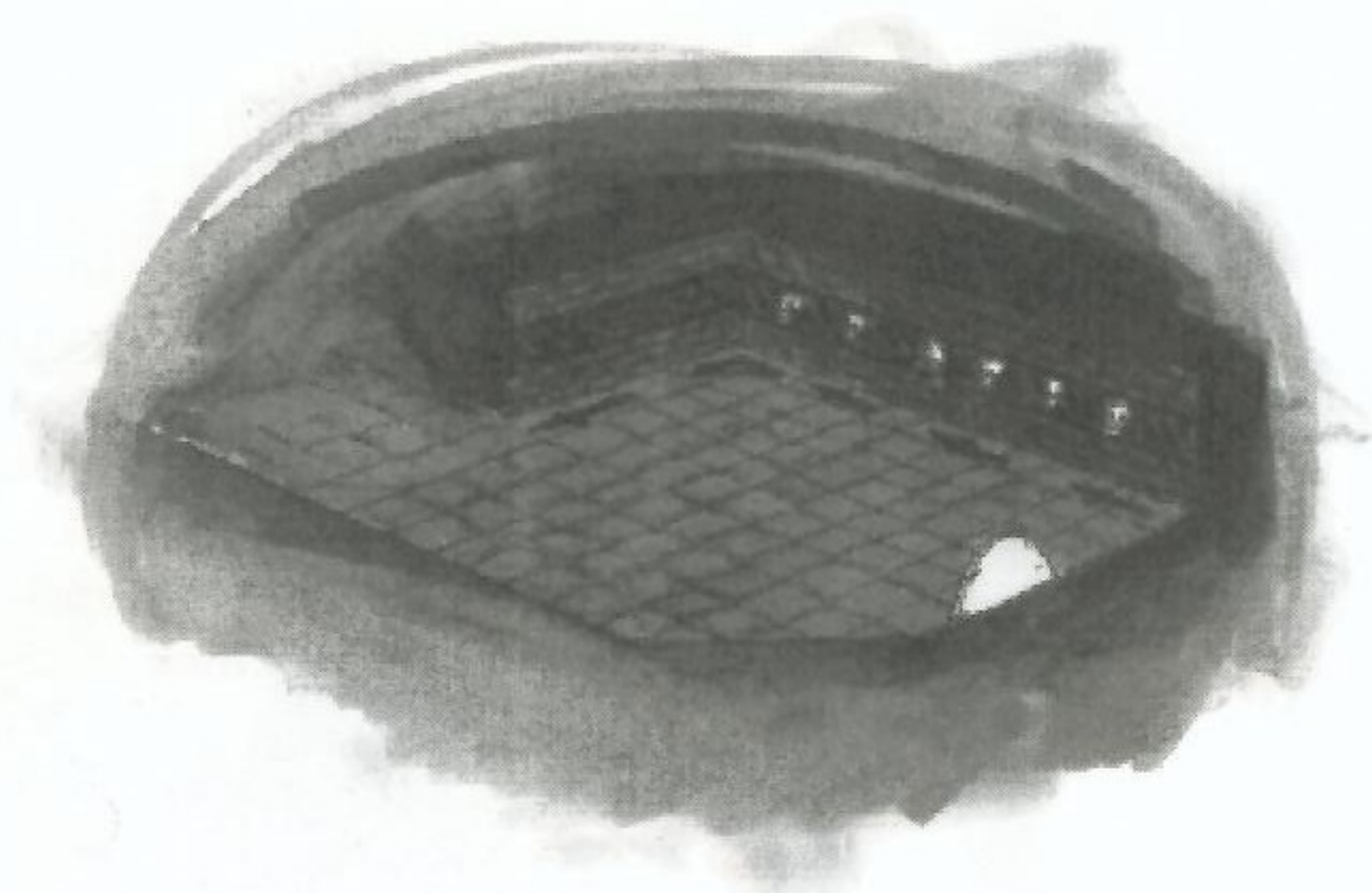

A safe path past the arrows. I got this far before I set off the trap.



Danger! Pit traps

In the dark room that follows are deadly creatures, invisible to the eye. Only their shadows can be seen in the light. Keep a torch lit and watch their movements carefully. They move quickly!

There are pit traps in this room as well.

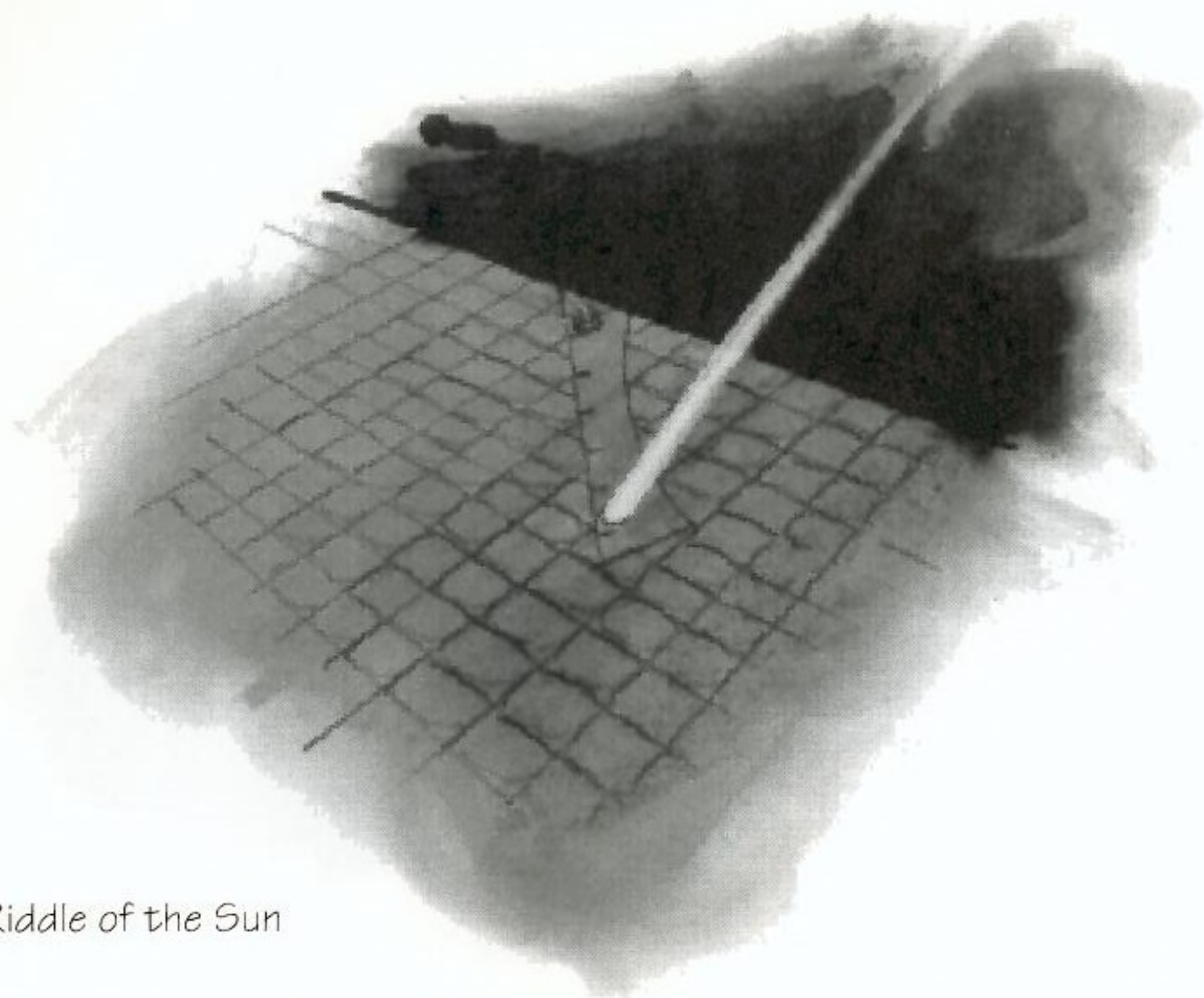

Riddle of the Sun

Deep in immortal Dragon's Lair
Once in one Millenium
The Portal opens to the Stair
When a single Gem greets the Sun

Mechanism tripped every thousand years by light.

Something shiny...

Level 2

From a text I found on the history of this evil place:

"... After two days of bitter combat, Arinar the Elven Lord escaped the enemy, but through his veins ran a fatal poison, drawn from the keen edge of the Shadowlord's blade. Arinar fled over the high mountains to the ruined city of Erinoch, where he entered the Labyrinth in search of the fabled Water, said by many to heal even the deepest wounds.

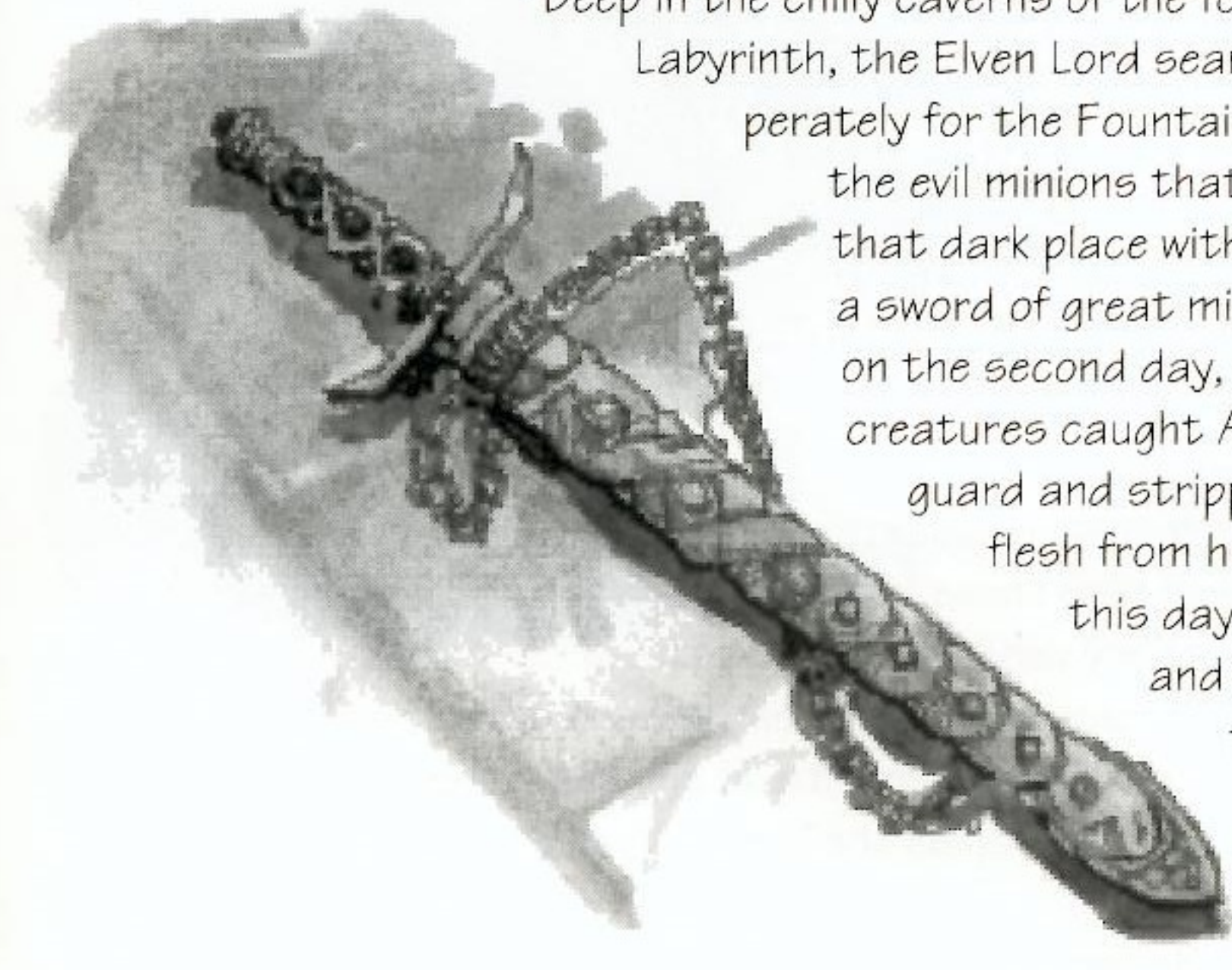

"Deep in the chilly caverns of the forgotten Labyrinth, the Elven Lord searched desperately for the Fountain, slaying the evil minions that dwell in that dark place with Solondul, a sword of great might. But on the second day, foul slime creatures caught Arinar off guard and stripped the flesh from his body. To this day his bones and sword lay there still..."



Legends have told of wayfarers being attacked by Will O' The Wisps. I reckoned such stories were the products of childish imaginations, but now I have seen these hateful creatures with my very eyes. I know little of their nature... Are they intelligent? Perhaps they are disembodied spirits of some sort, or maybe creatures of the elements. In any case, they are extremely dangerous — they despise the living and eagerly attack mortal flesh.

Maybe I can devise a spell to bring them under my control...

Spores — The goblins sometimes use them as a kind of weapon. When planted in soft dirt, these spores produce mushrooms that grow to waist height in a matter of seconds. The full grown mushrooms immediately fire more spores in a radius of 30

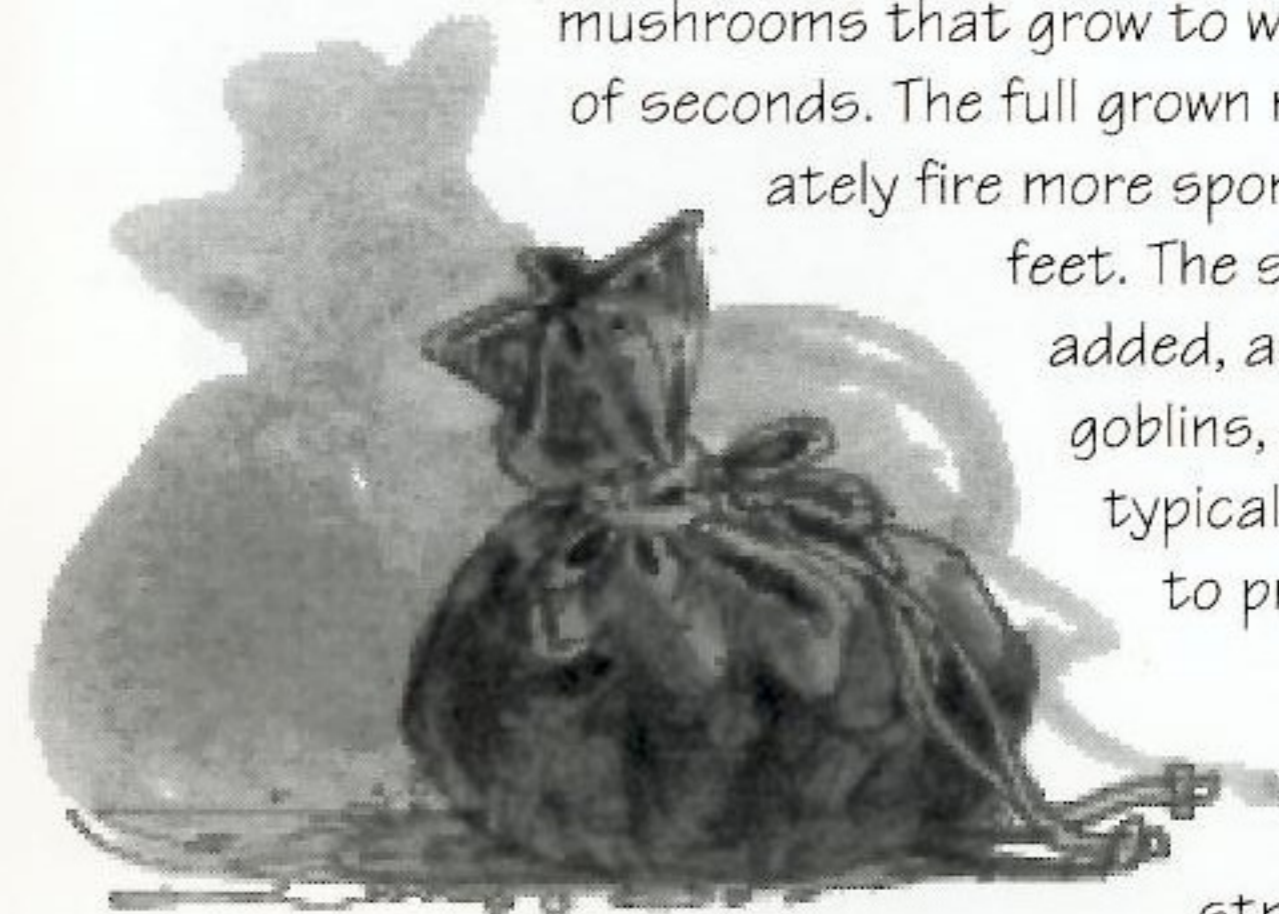

feet. The spores, it must be added, are deadly to humans, goblins, and trolls. The goblins typically carry them in sacks to protect themselves.

They can be recognized by their strong, sickening smell.

Years ago, when sorcerer's towers stretched toward the heavens and the Halls of Wizardry protected the knowledge of the spheres, the city of Erinoch had need of locksmiths. The most cunning locksmith, I recall, was a dwarf by the name of Lindli. His locks never involved anything as boring as a simple lock and key. Lindli's mechanisms required the unusual — finely crafted gems, beams of light, paces around an object...

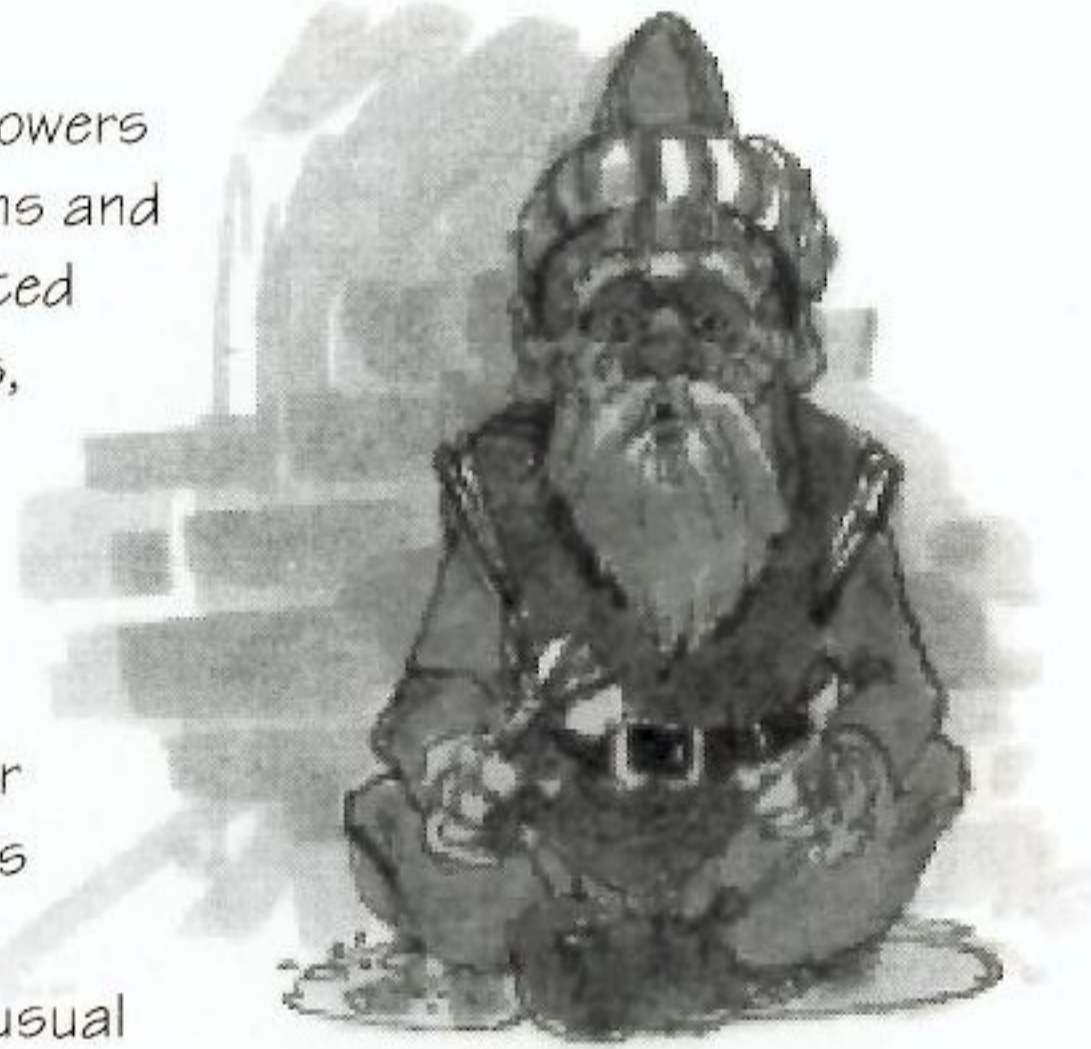

Lindli prospered while serving the wizards of Erinoch. But when the dragon came over 1000 years ago, his house was destroyed and his family perished in the flames. Lindli went quite mad after seeing the beast devastate his dreams, and he cursed the wizards who unleashed the dragon's wrath. He vowed to seal off the labyrinth forever so that men would no longer seek the Water...

The magic dust can be thrown to make an irritable old fool your friend.

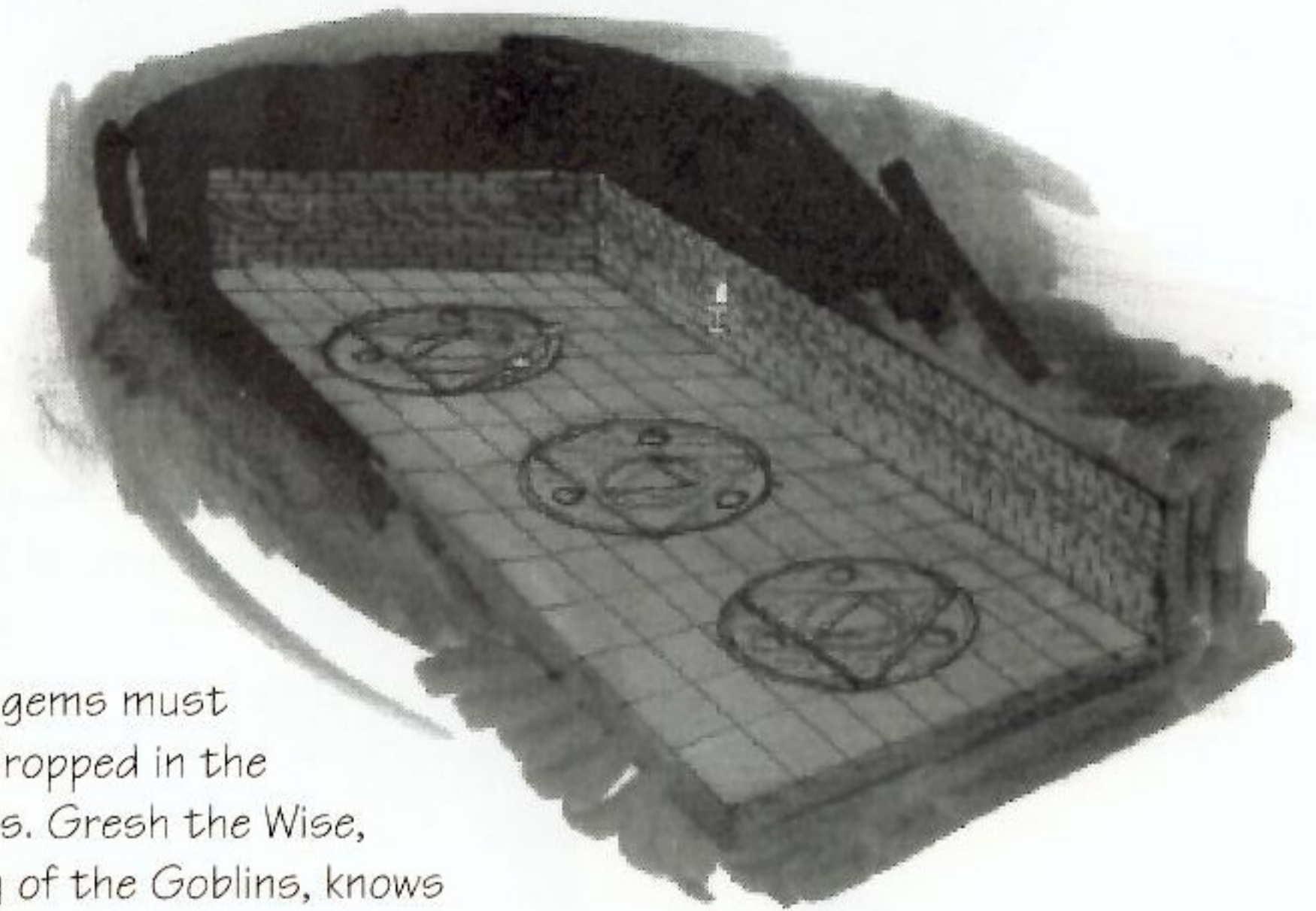

The gems must be dropped in the holes. Gresh the Wise, King of the Goblins, knows the combination. One must defeat him before he'll speak.

Level 3

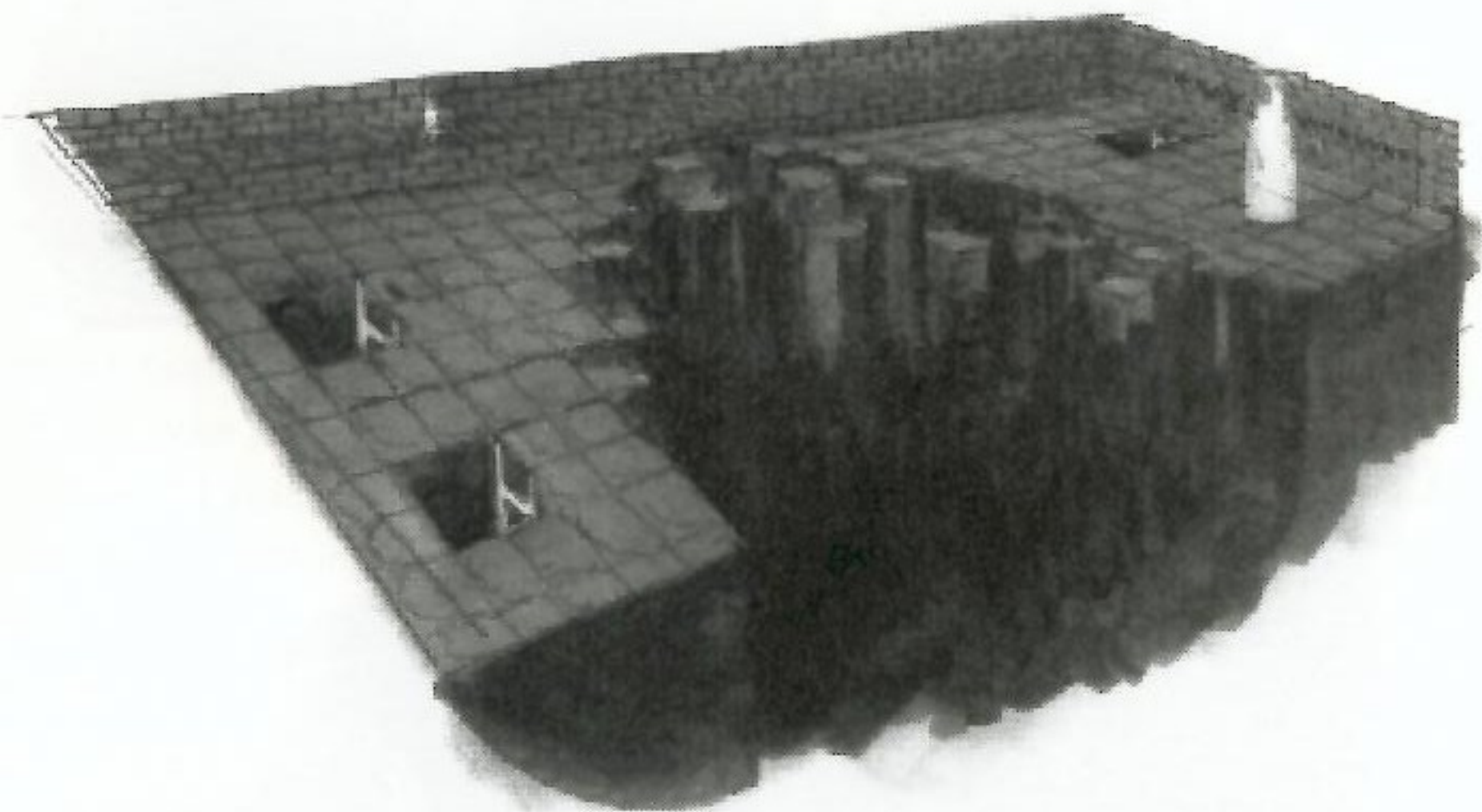

Only the fierce might of an angry dragon could split the earth and form this deep chasm. The crack cannot be crossed by rope — the brisk winds rising from the dragon's lair make it too dangerous! The only way across is a magic gate — a teleport mechanism — hidden in one of the rooms below. The shaft of light on the other side is where the magic gate leads.

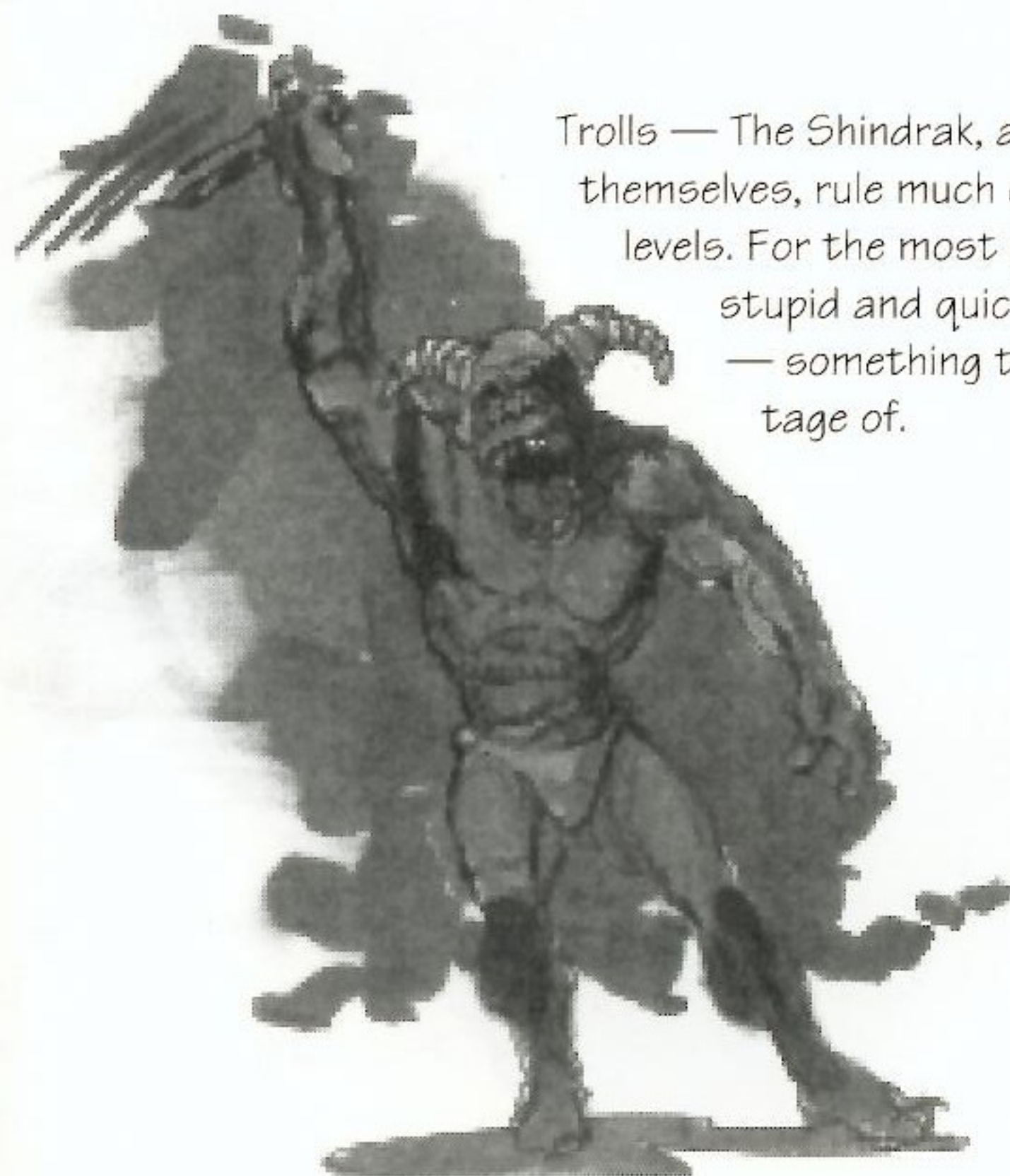

Trolls — The Shindrak, as they call themselves, rule much of the lower levels. For the most part, they are stupid and quick-tempered — something to take advantage of.



A troll will throw his ritual knife only when he wants to challenge another troll to combat.

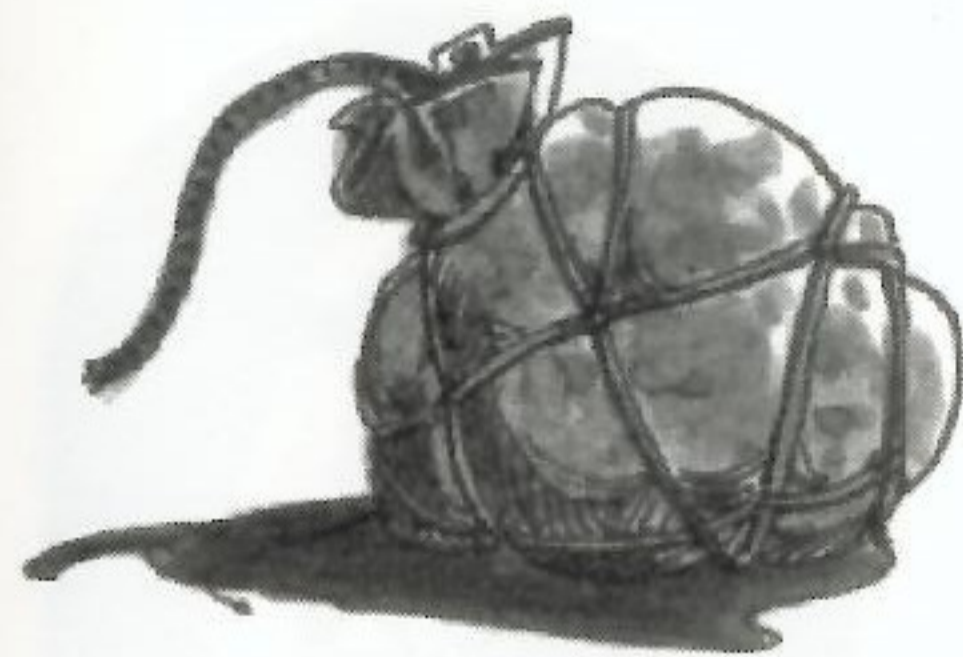

Troll bomb. One whiff of these devices and trolls are paralyzed.

Proteus, a god of the sea, was a master shape-changer who could travel disguised as fire and wild boars. This ring was forged by Proteus when the earth was young. It allows the wearer to take on the form of a goblin. Beware! Some are too wise to believe its charms!

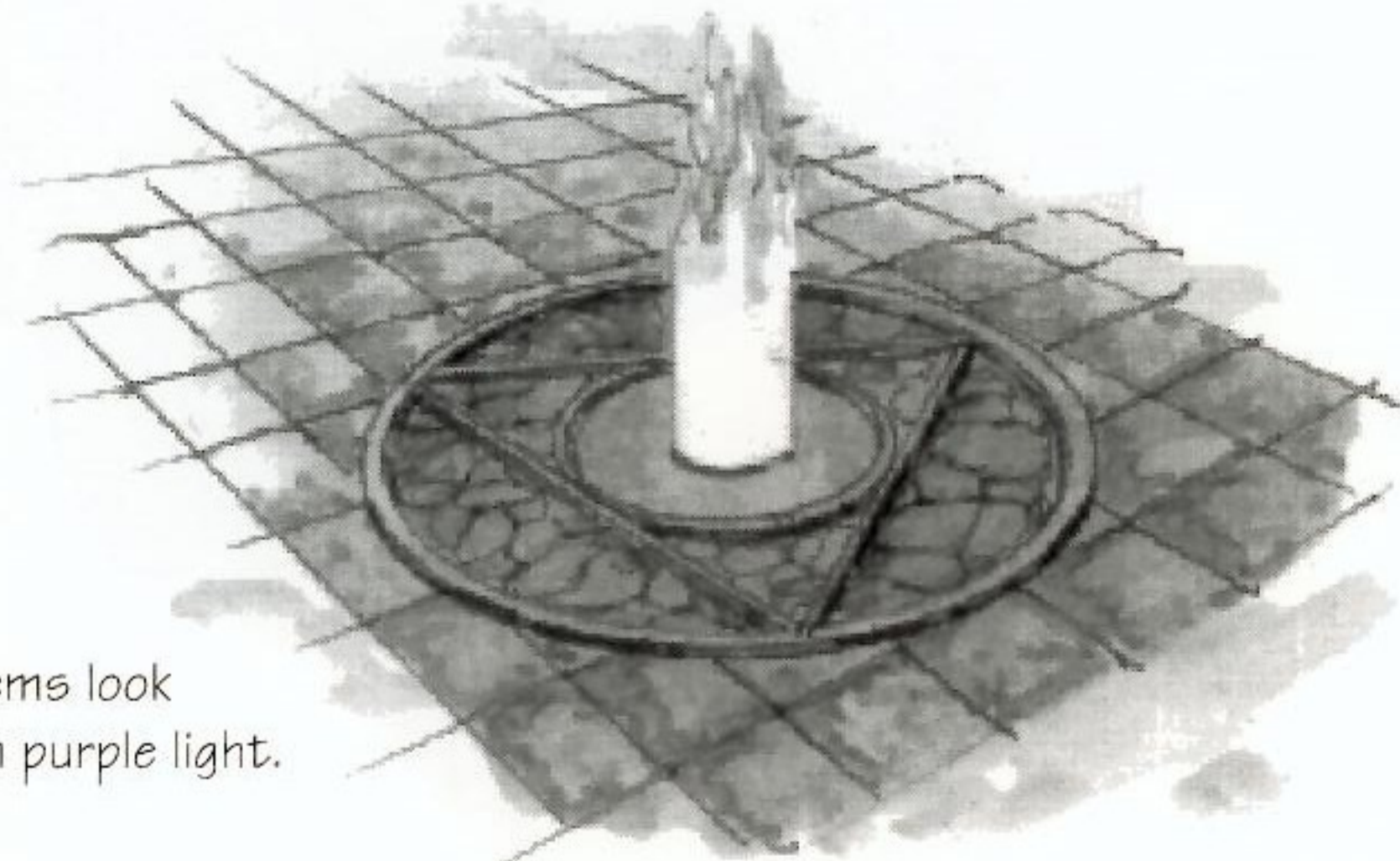
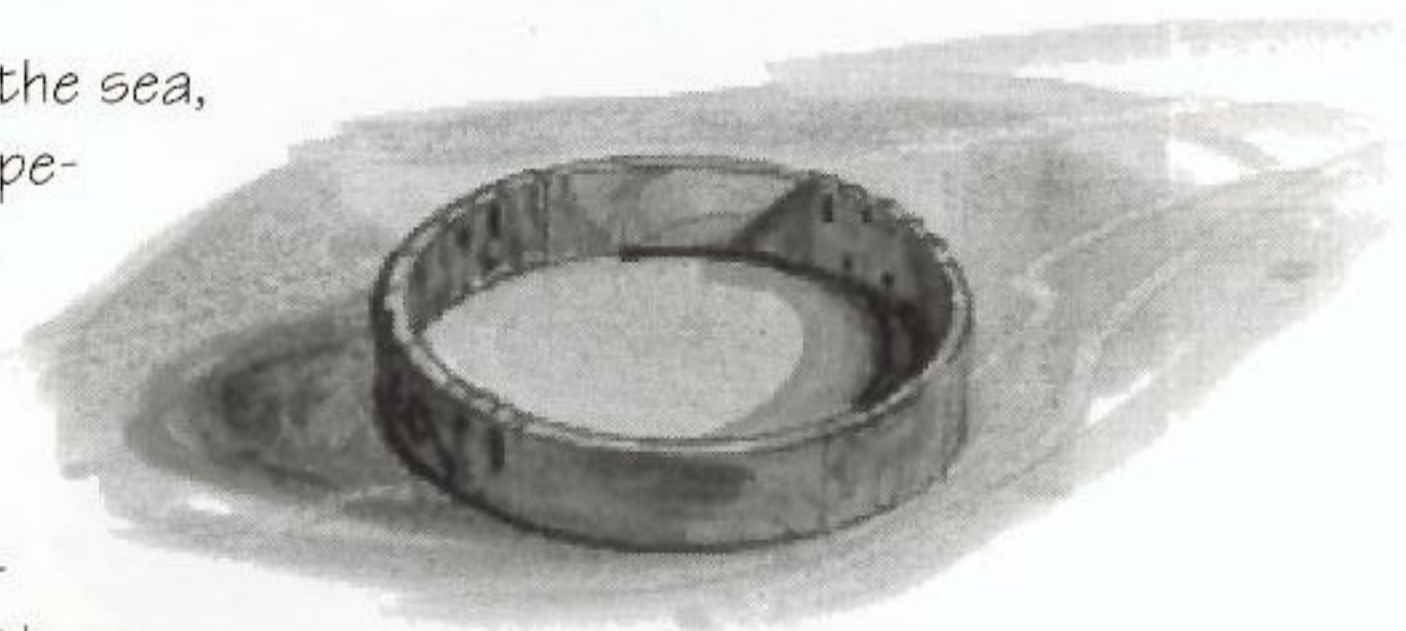

Red gems look best in purple light.

Level 4

When Dunric interfered with the trolls' battle against the goblins, they kidnapped his daughter, Ana, and dragged her into the labyrinth. As she possesses some of her father's skill in sorcery, she had no trouble escaping the trolls. But on her way out, she lost a special ring given to her by her father.

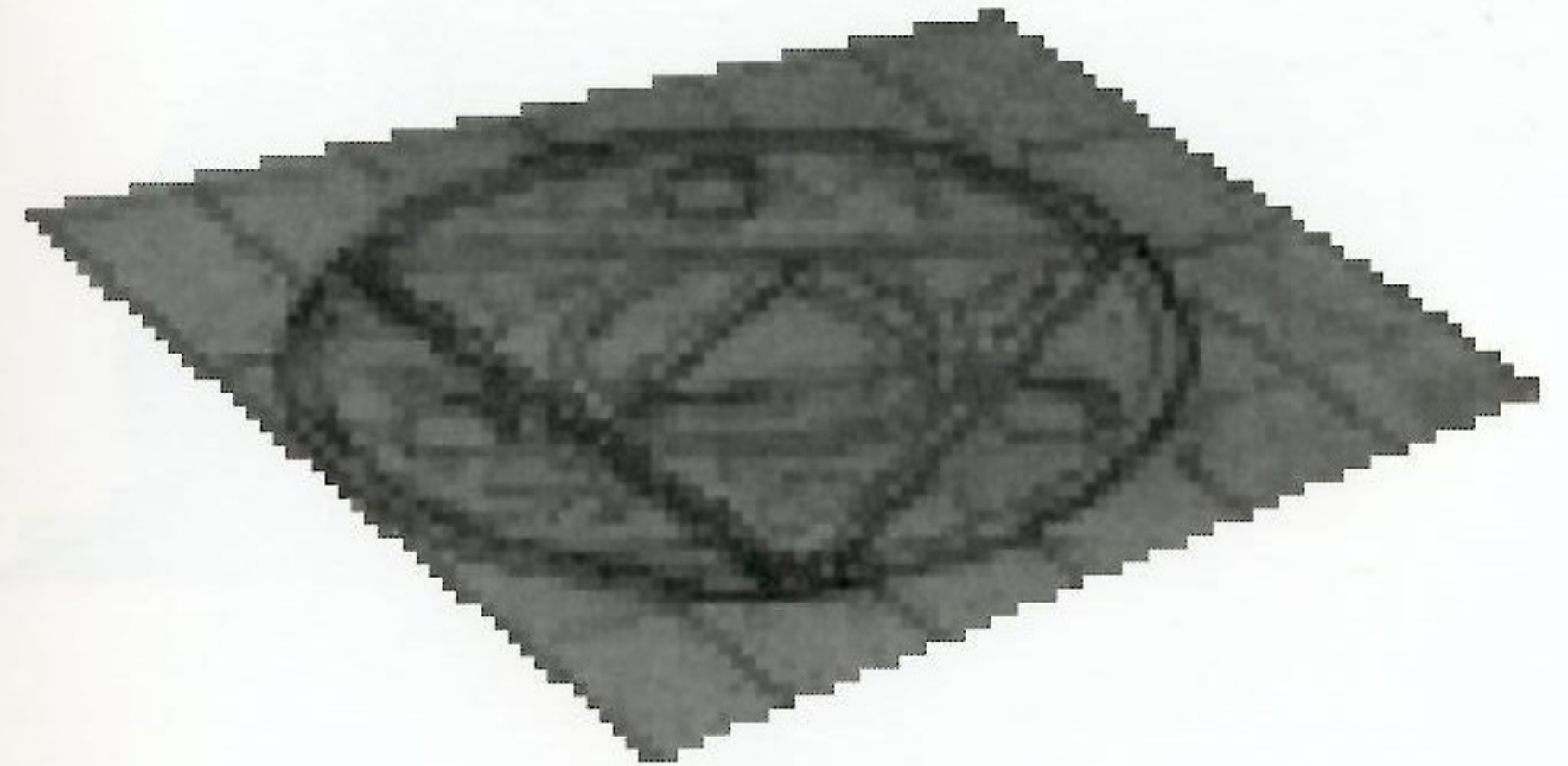

Some rings are never worn on the body.

Level 5

The potion transforms and poisons you at the same time. You will benefit from its power to shrink you, but you must find Water and drink it soon afterward or you'll never live past the hour.

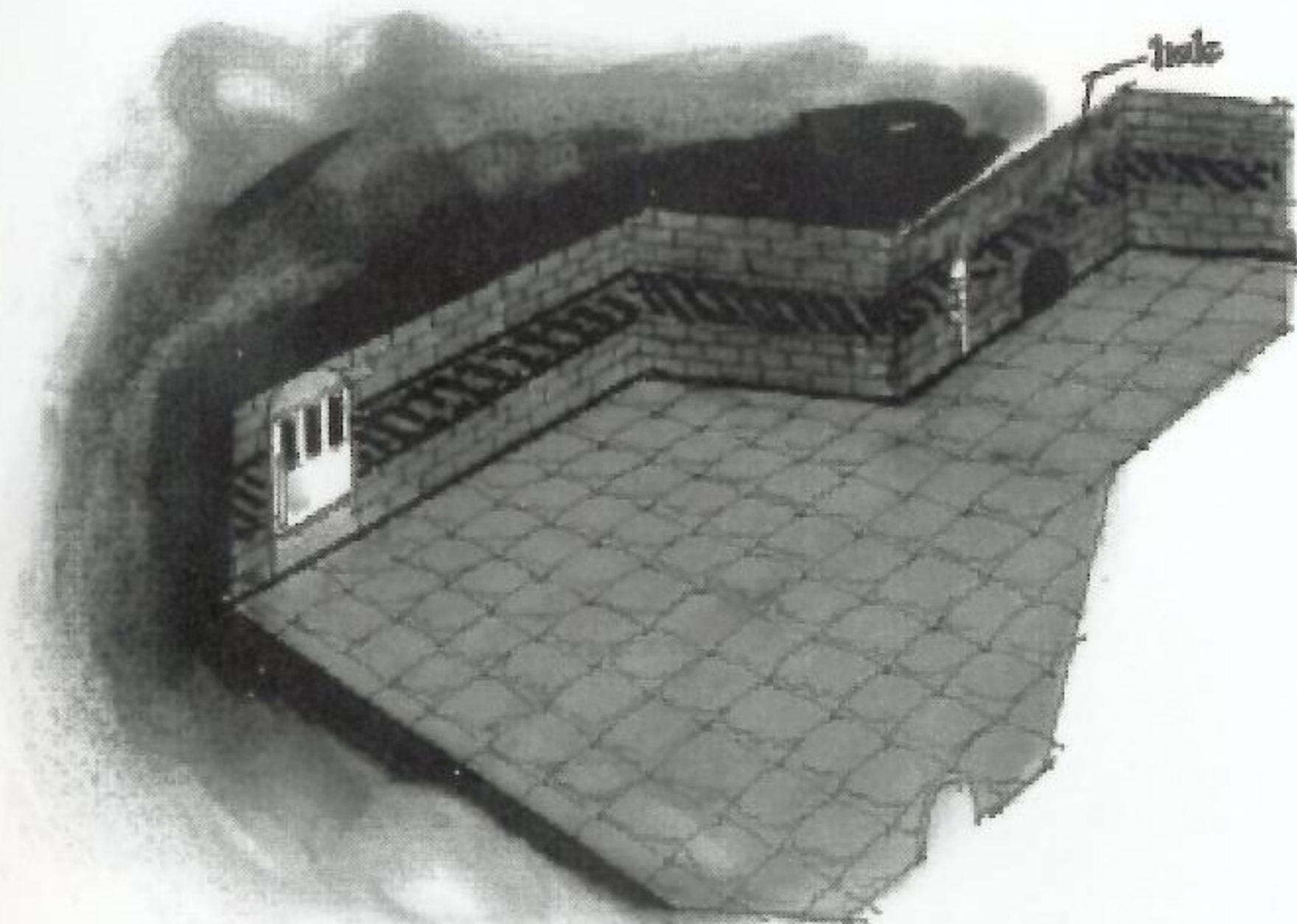
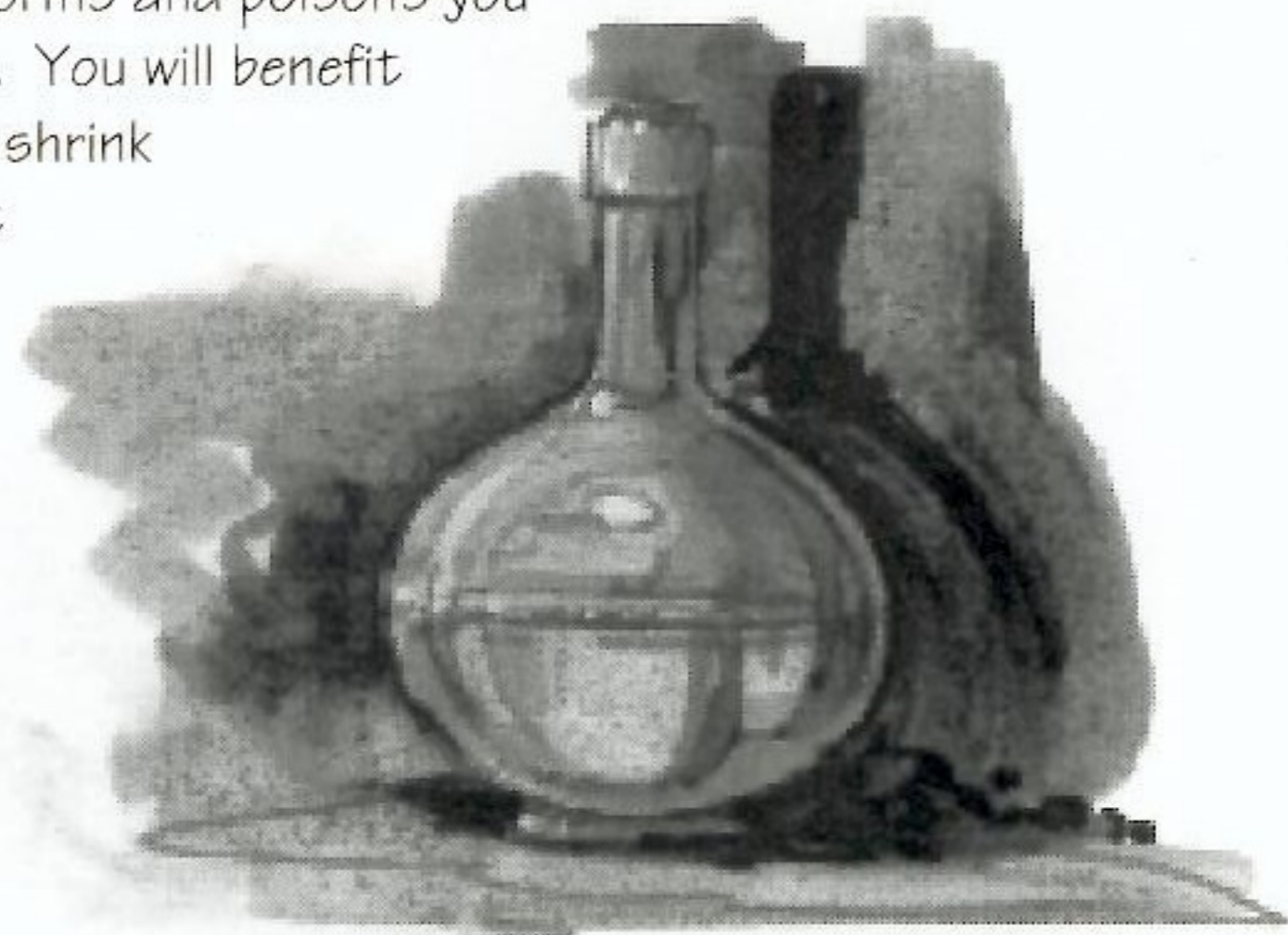

Many mice but fewer men can pass through a crack in the wall. This is the only way out of this level.

Worm sensor — The faster it chimes,
the greater your danger.



The weight of one will open the way. Set down food and a flying lizard
could hold the door.

Level 6

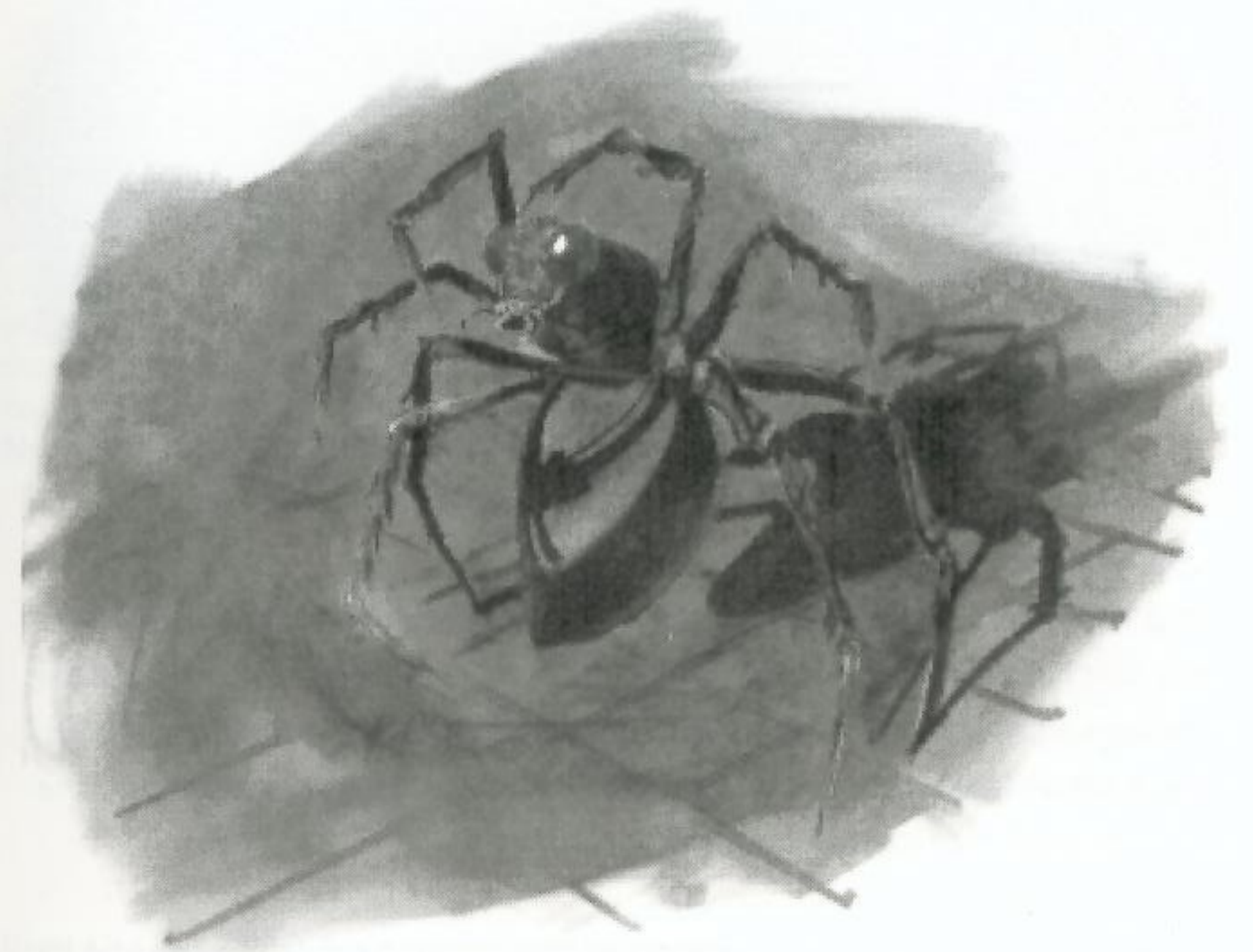

When she rears up, she's ready to web. Move back!

She's most vulnerable when all four legs are on the ground.

Now is not the time to imbibe spirits.

Level 7

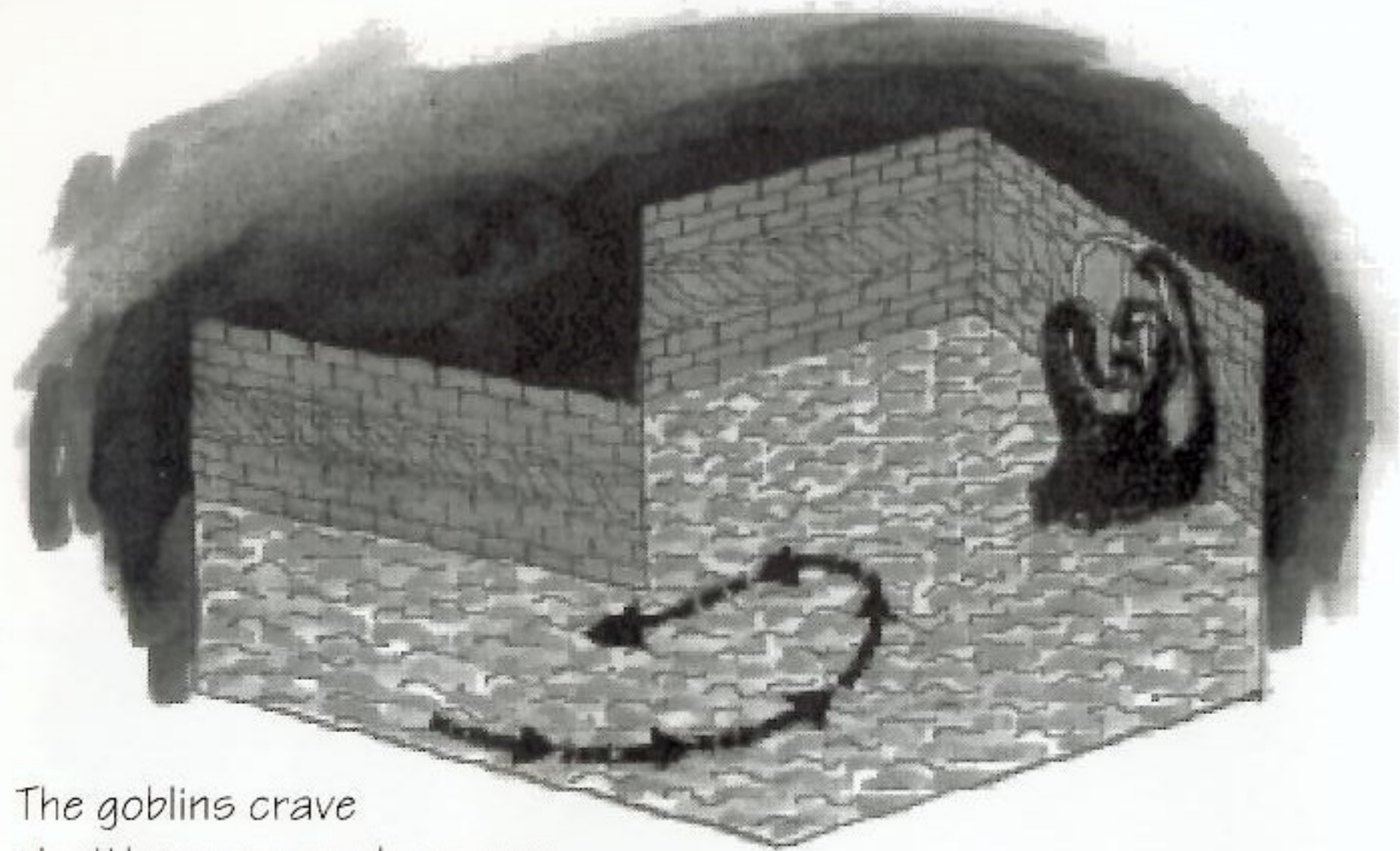

The goblins crave the Water as much as men, but a horrid water creature guards the way! If the water monster were distracted long enough, the goblins could open a gate and the creature would be washed away into the deepest underground sea. Only a wizard, adept at sailing, stands a chance of distracting the monster and making his escape.

This is the final step before entering the dragon's lair...do whatever you must to help the goblins open the way. Your journey is almost complete — if fortune finds us, we will stand together against the dragon!

Sandcastle Biography

Will Harvey started writing computer games in high school. After writing the hit, Music Construction Set, Will founded Sandcastle, which produced Zany Golf™ and now The Immortal™. Will is working towards writing the first interactive film. "It is more like a ride at Disneyland," he explains cryptically. Will is a PH.D. student in Artificial Intelligence at Stanford University.

Ian Gooding, a native of Jamaica, studied character animation at Cal Arts. Last year, he collaborated with Will on the animation and graphics of the miniature golf game, Zany Golf. Ian's unparalleled attention to detail comes through in all his work, from the bouncing hamburger hole in Zany Golf to the man eating worm in The Immortal. If you look really closely, you can see a signature in the Wizard's staff. Now Ian is working on animated films at Disney.

Michael Marcantel, was trained at Cal Arts in film graphics. After his school years, Michael applied his talents ranging from sign painting to making his own films. One year ago he joined Sandcastle to work on The Immortal. Michael is to credit for the rich and realistic rendering of the graphics. Michael is now visiting friends and studying the local color of Brazil.

Brett G. Durrett has been programming computers since High School. He quickly got involved in designing and programming computer games. Brett joined Sandcastle nine months ago to do versions of The Immortal and Zany Golf. Brett spends most of his free time purchasing small rodents and complaining about his hair.

Credits

Game Design: Sandcastle: Will Harvey, Ian Gooding, Michael Marcantel, and Brett G. Durrett.

Software: Will Harvey, Brent G. Durrett

Graphics: Ian Gooding and Michael Marcantel

Music: Doug Fulton

Producer: Don Traeger

Associate Producer: Jim Rushing

Assistant Producer: Happy Keller and Jon Horsley

Product Management: Christopher Thompson and David Bamberger

Art Director: Nancy Fong

Package Art: Gerald Chin

Documentation: David Luoto

Testing: Ed Gwynn, Steve Smythe, Mike Wallis, Orlando Guzman,

Manny Granillo, Kurtis Hsu

SOFTWARE © 1990 WILL HARVEY
ALL RIGHTS RESERVED.

MANUAL BY DAVID LUOTO

© 1990 ELECTRONIC ARTS. ALL RIGHTS RESERVED.

